

# Water Storage and Sedimentation Basins: Concept and Sizing

## 1. Introduction

A good water quality improvement strategy begins with the efficient management of inputs, the adoption of cropping practices that promote water infiltration to reduce soil erosion, and the establishment of effective buffer zones. To improve environmental performance, supplemental structures such as water storage and sedimentation basins can be built to trap eroded soil particles.

The purpose of this fact sheet is to explain how to determine the appropriate size for a water storage and sedimentation basin. This objective is different from that of the fact sheet entitled Inlet and Drainage Wells (Stampfli et al., 2007b), which focused mainly on structures to provide surface drainage or limit field gullyng.

Detailed information on the installation of piping and spillways is provided in the fact sheets entitled Inlet and Drainage Wells (Stampfli et al., 2007b) and Rock Chute Spillways (Lamarre, 2009).



Source: Victor Savoie (MAPAQ)

## 2. Definition

A water storage and sedimentation basin is a structure built in a field, at the edge of or within a water system (e.g. a ditch), but not in a watercourse. The purpose of such basins is to retain, permanently or temporarily, surface runoff loaded with soil particles and organic matter, in order to trap a portion of those materials through settling. The basin empties gradually by means of a drainage well that has underground piping and has been sized using clearly defined criteria. Water storage and sedimentation basins that are intended to drain completely between rain events are called dry ponds. This fact sheet deals mainly with this type of basin. Wet ponds, which have a larger capacity and contain a permanent pool of water, are even more effective for trapping nutrients and sediments, because these structures slow down flows better. More information on wet ponds, including design standards, is provided in the report by Rivard and Rinfret (2012), which was prepared as part of Agriculture and Agri-Food Canada's Climate Adaptation for Resilience in Agriculture project.

## 3. Theory of sizing water storage and sedimentation basins

This section presents the steps required to determine the minimum volume for a water storage and sedimentation basin using theoretical equations. The minimum volume is

the volume that allows the basin to trap a portion of the sediments targeted by the designer.

Section 4 then sets out things to consider for improving sediment and nutrient trapping using the results of empirical research. That greater environmental effectiveness is obtained by increasing the storage volume of the basins.

### 3.1 Selection of particle type for sedimentation

Water storage and sedimentation basins are designed to reduce the load of suspended particles in receiving watercourses and, if possible, to intercept a portion of the nutrients. The higher the flow rate to be managed or the smaller the target particles, the larger the basin will need to be. In practice, basins are generally sized to trap medium silt and coarser particles.

### 3.2 Determination of rate of discharge from the basin

The discharge rate that is used in designing a water storage and sedimentation basin must fit the runoff conditions that are usually observed during the most frequent rain events. The discharge rate is associated solely with the perforations in the vertical column of the drainage inlet.





The structure should not be designed with a discharge rate that is too high; for example, the discharge rate should not be equivalent to the total peak flow for short rain events that occur rarely (10-yr events). In such a case, the water storage and sedimentation basin would not control the flow, would permit sedimentation during only a few runoff events over the course of its useful life, and would require a large volume of storage.

Regardless of the volume of the basin, the flow rate through the perforations in the drainage inlet needs to be limited to promote sedimentation by controlling the peak flows of the most frequent rain events, with maximum depths of 20 to 25 mm, as described in Section 4. The resulting runoff events generally have moderate peak flows, as indicated in Table 1.

Table 1: Mean peak flows measured in agricultural plots and associated with rain depths of 20 to 25 mm (Guillou, 2012).

Site	Number of events measured	Area (ha)	Mean peak flow (m <sup>3</sup> /s)
Berna	n = 7	7.2	0.027
Landry	n = 6	7.1	0.020

Currently, Hickenbottom inlets are widely used in Quebec because they provide an efficient surface drainage and limit field gullyng. However, their discharge rate is generally too high for retaining runoff water and promoting sedimentation, as indicated in Table 2, which was prepared using measurements from the University of Guelph (OMAFRA, 2008). For that reason, inlets of SolTrap or Hickenbottom type should be avoided in sedimentation projects. The discharge rate of such inlets can be limited by the addition of a diaphragm, but the clogging of this device with residues makes the structure inoperative and causes runoff and erosion from overflow.

Table 2: Flow rates of Hickenbottom inlet wells without diaphragms, in m<sup>3</sup>/s, according to hydraulic head, without clogging by residues (OMAFRA, 2008).

Height of water above ground (m)	Inlet well 150 mm	Inlet well 200 mm
0.30	0.020	0.027
0.61	0.043	0.065
0.91	0.057	0.095

The HEC-HMS v. 3.5 software package (USACE, 2010) was used to compare the discharge of a 200-mm Hickenbottom

inlet and a drainage inlet with perforations during the runoff from a 25-mm rainfall in a 7.2-ha watershed under annual crops (Berna site). As shown in Figure 1, the Hickenbottom inlet had virtually no effect in terms of reducing flow rate and storing runoff water.

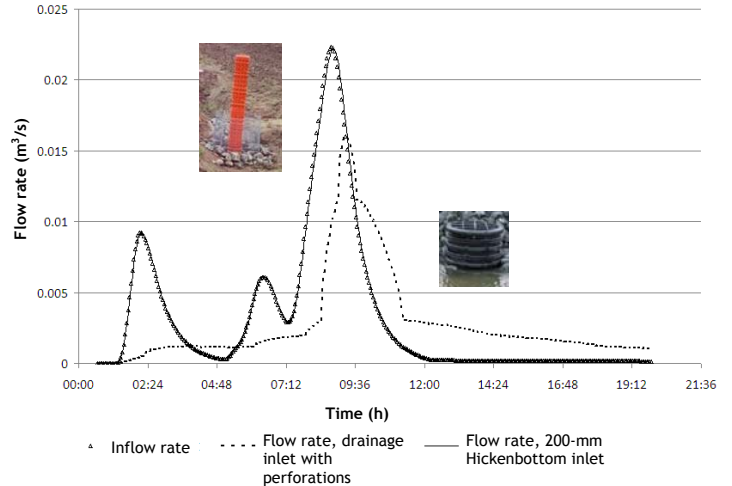

Figure 1: Hydrograph measured in the Berna plot (triangles) and rates of discharge by a Hickenbottom inlet (solid line) and a drainage inlet with perforations (broken line).

For a reduction in peak flow and the storage of water during runoff events associated with frequent rain events, a water storage and sedimentation basin should use a drainage inlet with perforations in the vertical column that permit theoretical drainage of 5% of the 10-yr peak flow, for rain of equal duration to the concentration time.

This discharge rate will be used as the basis for calculating the minimum water storage volume (Sections 3.3, 3.4, and 3.6) and for determining the number of perforations required in the vertical column of the drainage inlet (Section 6).

The 10-yr peak flow, on which the calculation is based, will be assessed in accordance with the characteristics of the watershed (soil type, crop, slope, size of drainage basin, length of watercourse), as indicated in the fact sheet entitled Evaluation of Peak Flows for Small Agricultural Drainage Basins in Quebec (Stampfli et al., 2007a). The intensity of 10-yr rains for various weather stations in Quebec can be found on the AgroMétéo Québec website (Mailhot et al., 2011) or the Climat-Québec website (Environment Canada) if any data are missing.

- <http://dev.agrometeo.org/atlas/idf/true/true> (in French only)
- [http://www.climat-quebec.qc.ca/home.php?id=carte\\_idf&mpn=stats&lg=en](http://www.climat-quebec.qc.ca/home.php?id=carte_idf&mpn=stats&lg=en)





### 3.3 Calculation of minimum area of the water storage and sedimentation basin

Sedimentation velocities ( $V_p$ ) are generally calculated using Stoke's law, shown in Equation 1, from the mass density and diameter of the particle and the density of the fluid containing it (MDDEP, 1997). Sedimentation velocities are also provided for reference purposes in Table 3, but the values differ slightly from the results obtained with Equation 1, because different soil particle density values were used.

**Equation 1**  
Calculation of vertical fall velocity of particles:

$$V_p = \frac{[g \times (\rho_p - \rho_e) \times d^2]}{(18 \times h)}$$

where

- V<sub>p</sub>**: vertical fall velocity of particles (m/s)
- g**: gravitational acceleration (9.81 m/s<sup>2</sup>)
- ρ<sub>p</sub>**: soil particle density (kg/m<sup>3</sup>)
- ρ<sub>e</sub>**: mass density of water (1000 kg/m<sup>3</sup>)
- d**: diameter of particles for sedimentation (m)
- h**: dynamic viscosity of water at 4°C (0.0016 Pa.s)

The sedimentation times within a 1-m-high water column for different soil particle diameters are presented in Table 3. A water storage time of several hours allows a major portion of silts to be retained. However, the sedimentation of clay particles is not a very realistic objective. Because sedimentation basins are built near or in cultivated areas, the water retention time must be within the crop's tolerance for submersion (24 h for field crops and 12 h for canning crops).

To slow runoff, the water storage and sedimentation basin must have an adequate minimum water area ( $A_s$ ). That area is determined using Equation 2 (MAPAQ, 1990) and is illustrated in Figure 2.

**Equation 2**  
Calculation of minimum water area in basin:

$$A_s = \frac{\Theta \times Q}{V_p}$$

where

- A<sub>s</sub>**: minimum water area in basin (m<sup>2</sup>)
- Q**: discharge rate (m<sup>3</sup>/s) corresponding to 5% of 10-yr peak flow
- Θ**: adjustment factor related to turbulence (Θ takes the value of 1, 1.2, or 1.5 depending on the degree of turbulence in the sedimentation basin)
- V<sub>p</sub>**: sedimentation velocity (m/s)

When a water storage and sedimentation basin is being designed, an elongated shape is recommended (length/width ratio greater than 2) to promote plug flow in the basin (Rivard and Rinfret, 2012).

The width of the water surface ( $W$ ) can be calculated using Equation 3 for a trapezoidal canal, and the minimum length of the basin ( $l$ ) can be calculated using Equation 4. The water depth ( $P$ ) is selected initially by the designer and represents the water height planned in the basin before overflow, on the basis of the topography of the field or the existing ditch.

**Equations 3 and 4**  
Calculation of width of water surface (Equation 3):

$$W = L + 2 \times P \times z$$

Calculation of minimum length of basin (Equation 4):

$$l = A_s \div W$$

where

- W**: width of water surface (m)
- L**: width at floor of basin (m)
- P**: water depth in basin during operation (m)
- z**: slope of sides (for 1:1.5, z = 1.5)
- l**: minimum length of basin (m)
- A<sub>s</sub>**: minimum water area in basin (m<sup>2</sup>)

For references purposes, the settling time, which is the time required for the soil particles to reach the floor of the basin, can be deduced by dividing the depth of the basin ( $P$ ) by the sedimentation velocity of the soil particles ( $V_p$ ).



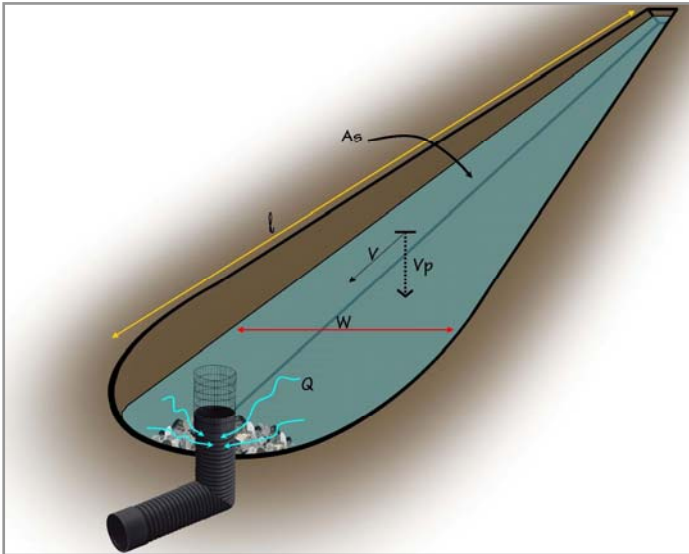

Figure 2: Basic parameters for a water storage and sedimentation basin.

### Example of the sizing of a water storage and sedimentation basin

This calculation example will be used throughout the fact sheet to illustrate how to size the various elements of a water storage and sedimentation basin. In the case described here, the basin is being built inside an existing agricultural ditch.

#### Basic data

- Watershed with minimal slope:  $A = 5$  ha
- 10-yr peak flow:  $Q_p = 0.12$  m<sup>3</sup>/s
- Particles for sedimentation: medium silt
- Soil particle density :  $\rho_p = 2633$  kg/m<sup>3</sup>
- Diameter of particles for sedimentation:  $d = 2 \cdot 10^{-5}$  m
- Discharge rate:  $Q = 5\% \times Q_p = 0.006$  m<sup>3</sup>/s
- Width at floor of basin:  $L = 0.6$  m
- Slope of sides: 1:1.5, therefore batter  $z = 1.5$
- Water depth during operation:  $P = 0.6$  m

#### Calculation steps

Equation 1, Calculation of fall velocity:  $V_p$

$$V_p = \frac{[9.81 \times (2633 - 1000) \times (2 \cdot 10^{-5})^2]}{(18 \times 0.0016)} = 0.000222 \text{ m/s}$$

Equation 2, Minimum area of basin:  $A_s$

$$A_s = 1.2 \times 0.006 \div 0.000222 = 32 \text{ m}^2$$

Equation 3, Width of water surface:  $W$

$$W = 0.6 + 2 \times 0.6 \times 1.5 = 2.4 \text{ m}$$

Equation 4, Minimum length of basin:  $l$

$$l = 32 \div 2.4 = 14 \text{ m}$$

### 3.4 Calculation of minimum depth of the water storage and sedimentation basin

Once the particles have settled to the basin floor, it is necessary to keep them from becoming resuspended, by reducing the water circulation velocity inside the basin (tangential velocity,  $V$ ) to a level below the velocity at which particle resuspension will occur (entrainment velocity,  $V_e$ ). To achieve this objective, sufficient water depth and sufficient flow area must be maintained in the basin during the most frequent rain events. These elements are illustrated in Figure 3.

In all cases, the minimum water depth recommended in a water storage and sedimentation basin is 0.6 m, in order to reduce turbulence and promote the sedimentation of soil particles. That depth is frequently found in basins built inside existing agricultural ditches.

For validation purposes, the entrainment velocity of soil particles ( $V_e$ ) can be determined using Equation 5 (MDDEP, 1997) or found in Table 3. The link between the flow area in the basin ( $A_i$ ) and the entrainment velocity ( $V_e$ ) is shown in Equation 6 (continuity equation). Equation 7 is used to calculate the flow area for a trapezoidal canal. Then, the minimum water depth in the basin ( $p$ ), for which the entrainment velocity ( $V_e$ ) is equal to the tangential velocity ( $V$ ), can be solved by iteration using Equation 8. If greater than 0.6 m, the result of Equation 8 is selected for the design of the water storage and sedimentation basin. Subsequently, the flow area ( $A_i$ ) is calculated using Equation 7, taking into account the depth ( $p$ ) that was selected.

#### Equation 5

Calculation of entrainment velocity:

$$V_e = [8 \times k \times (s - 1) \times g \times (d \div f)]^{0.5}$$

where

- $V_e$ :** entrainment velocity (m/s)
- $k$ :** constant based on particles (0.04 to 0.06)
- $s$ :** soil particle density (T/m<sup>3</sup>)
- $g$ :** gravitational acceleration (9.81 m/s<sup>2</sup>)
- $d$ :** diameter of particles for sedimentation (m)
- $f$ :** constant based on surface (0.02 to 0.03)





**Equations 6, 7, and 8**

Continuity equation (Equation 6):

$$A_i = Q \div V_e$$

Calculation of flow area for trapezoidal canal (Equation 7):

$$A_i = [L + (p \times z)] \times p$$

Calculation of minimum water depth in basin (m) (Equation 8):

$$\text{Therefore } p = (Q \div V_e - p^2 \times z) \div L$$

where

- A<sub>i</sub>:** flow area in basin (m<sup>2</sup>)
- Q:** discharge rate (m<sup>3</sup>/s) corresponding to 5% of 10-yr peak flow
- V<sub>e</sub>:** entrainment velocity of soil particles (m/s)
- L:** width at floor of basin (m)
- z:** slope of sides (batter)
- p:** minimum water depth in basin (m)

Subsequently, Equation 9 can be used to calculate the minimum water volume in the basin (V<sub>1</sub>), taking into account the water depth selected (p).

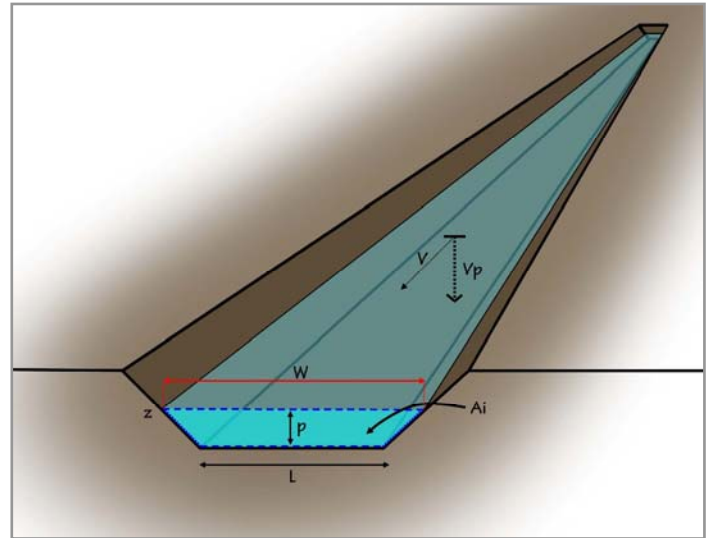

Figure 3: Minimum water depth and flow area.

**Equation 9**

Calculation of minimum water volume in basin:

$$V_1 = A_i \times l$$

where

- V<sub>1</sub>:** water storage volume in basin (m<sup>3</sup>)
- A<sub>i</sub>:** flow area in basin (m<sup>2</sup>)
- l:** minimum length of basin (m)

Table 3: Sedimentation velocities and entrainment velocities of soil particles (adapted from MAPAQ, 1990; Goldman et al., 1986; MDDEP, 1997; Musy and Soutter, 1991).

Particle type	Diameter of particles for sedimentation (mm)	Soil particle density (kg/m <sup>3</sup> )	Sedimentation velocity (Goldman et al., 1986) (V <sub>p</sub> , m/s)	Sedimentation time in 1-m water column	Entrainment velocity (V <sub>e</sub> , m/s)
Coarse sand	0.5	2700	0.058	17 s	0.37
Medium sand	0.2	2681	0.020	50 s	0.23
Fine sand	0.1	2665	0.007	2 min	0.16
Coarse silt	0.05	2650	0.0019	9 min	0.11
Medium silt	0.02	2633	0.00029	57 min	0.07
Fine silt	0.01	2617	0.000073	3.8 h	0.05
Very fine silt	0.005	2600	0.000018	15.4 h	0.04
Clay	0.002	2325	1.80531E-06	6.4 d	0.02





## Example of the sizing of a water storage and sedimentation basin

### Basic data

- *Particles for sedimentation:* medium silt
- *Constant based on particles:*  $k = 0.05$
- *Soil particles density :*  $s = 2.63 \text{ T/m}^3$
- *Diameter of particles for sedimentation:*  $d = 2 \cdot 10^{-5} \text{ m}$
- *Constant based on surface:*  $f = 0.025$
- *Discharge rate:*  $Q = 5\% \times Q_p = 0.006 \text{ m}^3/\text{s}$
- *Width at floor of basin:*  $L = 0.6 \text{ m}$
- *Slope of sides:* 1:1.5, therefore batter  $z = 1.5$
- *Water depth during operation:*  $P = 0.6 \text{ m}$
- *Fall velocity:*  $V_p = 0.000222 \text{ m/s}$
- *Minimum length of basin:*  $l = 14 \text{ m}$

### Calculation steps

Equation 5, Calculation of entrainment velocity:  $V_e$

$$V_e = [8 \times 0.05 \times (2.63 - 1) \times 9.81 \times (2 \cdot 10^{-5} \div 0.025)]^{0.5}$$

$$V_e = 0.07 \text{ m/s}$$

Equation 8, Calculation of minimum water depth in basin:  $p$

$$p = (0.006 \div 0.07 - p^2 \times 1.5) \div 0.6$$

Calculation of the value of  $p$  by iteration

Equation 8 works out to  $p = 0.10 \text{ m}$ .

Because this result is lower than the required minimum of 0.6 m, the mean minimum water depth in the basin will need to be 0.6 m.

Equation 7, Calculation of flow area for a given water depth:  $A_i$

$$p = 0.6 \text{ m}$$

$$A_i = [0.6 + (0.6 \times 1.5)] \times 0.6 = 0.9 \text{ m}^2$$

Equation 9, Calculation of minimum water volume in basin:  $V_1$

$$V_1 = 0.9 \times 14 = 13 \text{ m}^3 \text{ (or } 3 \text{ m}^3 \text{ per hectare in the drainage basin)}$$



Source: Victor Savoie (MAPAQ)

## 3.5 Calculation of additional volume required for sediment storage

A basin's water storage capacity decreases gradually as sediments accumulate. To maintain the effectiveness of the basin, additional storage volume ( $V_2$ ), which is calculated using Equation 10, must be included. The additional storage volume must take into account the annual volume of soil that is eroded, on the basis of the area of the drainage basin, the slope, the crop, the type of tillage, and the time between cleanouts. The additional storage volume can be estimated using Table 4, which has been prepared using the Universal Soil Loss Equation, and taking into account the worst conditions encountered in the watershed and a period between cleanouts of 3 to 5 yr. The amount can be converted from tonnage to volume using a sediment density of  $1.47 \text{ T/m}^3$  (OMAFRA, 2008).

### Equation 10

Calculation of storage volume for sediments:

$$V_2 = T \times A \times D \div 1.47 \text{ T/m}^3$$

where

- $V_2$ :** storage volume for sediments ( $\text{m}^3$ )
- $T$ :** soil losses ( $\text{T/ha/yr}$ )
- $A$ :** area of watershed ( $\text{ha}$ )
- $D$ :** time between cleanouts ( $\text{yr}$ )



Table 4: Soil losses (T/ha/yr) depending on soil texture, slope, crop and tillage (adapted from OMAFRA, 2008).

	<i>Loam, silty loam, very fine sandy loam</i>	<i>Clay loam, silty clay loam, sandy clay loam</i>	<i>Sandy loam, fine sand</i>	<i>Clay</i>
<b>0% to 2% slope</b>				
Soybean, tilled	5.7	3.4	2.5	0.6
Grain corn, tilled	4.1	2.5	1.8	0.5
Soybean, direct-seeded	3.0	1.8	1.3	0.3
Grain corn, direct-seeded	1.0	0.6	0.5	0.1
Prairie	0.5	0.3	0.2	0.1
<b>2% to 5% slope</b>				
Soybean, tilled	15.4	9.2	6.8	1.8
Grain corn, tilled	11.2	6.7	5.0	1.3
Soybean, direct-seeded	8.1	4.9	3.6	0.9
Grain corn, direct-seeded	2.8	1.7	1.2	0.3
Prairie	1.4	0.8	0.6	0.2
<b>5% to 9% slope</b>				
Soybean, tilled	38.8	23.3	17.2	4.4
Grain corn, tilled	28.2	16.9	12.5	3.2
Soybean, direct-seeded	20.5	12.3	9.1	2.3
Grain corn, direct-seeded	7.1	4.2	3.1	0.8
Prairie	3.5	2.1	1.6	0.4

This additional volume for the temporary storage of sediments can be created by excavating or widening an existing ditch. The sides of the basin should be moderately sloped (generally 1:1.5 to 1:2) and be grassed as soon as construction is finished, in order to limit erosion. If the basin is located near inhabited areas or roadways, side slopes less than 1:3 may be required to reduce risks to people and goods.

The final dimensions of the water storage and sedimentation basin (width, total depth, slope of sides) will be tailored by the designer to accommodate the storage volumes for water (V1) and sediments (V2).

- If the basin is built in a long ditch with a minimally sloping floor, the basin's maximum water storage length (Lt) will be affected by the water depth at the outlet (Pt), near the drainage inlet, and by the slope of the basin floor. The maximum water storage length is calculated using Equation 11, and the total volume in the basin is calculated using Equation 12 (addition of the volumes of a prism and two tetrahedrons).

**Equations 11 and 12**

**Calculation of maximum storage length of basin (Equation 11):**

$$l_t = P_t \times 100 \div S$$

**Calculation of total volume in basin (Equation 12):**

$$V_t = L_t \times P_t \times l_t \div 2 + 1/3 \times P_t^2 \times z \times l_t$$

where

- Vt:** total volume in basin (m<sup>3</sup>)
- lt:** maximum storage length of basin (m)
- Pt:** total depth of basin near drainage well (m)
- S:** slope of basin floor (%)
- Lt:** final width at floor of basin (m)
- z:** slope of sides (for 1:1.5, z = 1.5)





- For a basin whose length was determined by the designer, the total volume is calculated instead using Equations 13 and 14, taking into account the mean of the flow areas at the upstream and downstream ends of the basin, as well as its planned length.



Basin built in an agricultural ditch.

Source: Victor Savoie (MAPAQ)

#### Equations 13 and 14

Calculation of total depth of basin at upstream end (Equation 13):

$$P' = Pt - Lt \times S \div 100$$

Calculation of total volume in basin (Equation 14):

$$Vt = \{[Lt + (Pt \times z)] \times Pt + [Lt + (P' \times z)] \times P'\} \div 2 \times Lt$$

where

- Vt:** total volume in basin (m<sup>3</sup>)
- lt:** maximum storage length of basin, determined by the designer (m)
- Pt:** total depth of basin near drainage inlet (m)
- P':** total depth of basin at upstream end (m)
- S:** slope of basin floor (%)
- Lt:** final width at floor of basin (m)
- z:** slope of sides (for 1:1.5, z = 1.5)

### Example of the sizing of a water storage and sedimentation basin

Note: In this example, the volume available in the existing ditch greatly exceeds the minimum required according to the calculations for storing runoff and sediments.

#### Basic data

- Watershed with minimal slope: A = 5 ha
- Time between cleanouts: D = 5 yr
- Soil losses: T = 4.1 T/ha/yr  
Loam soil with low slope (<2%), cropped with tilled grain corn
- Slope of basin floor: S = 0.2%
- Total depth of basin: Pt = 0.7 m
- Final width at floor: Lt = 0.6 m
- Slope of sides: 1:1.5, therefore batter z = 1.5
- Minimum water volume in basin: V1 = 13 m<sup>3</sup>

The values for Pt, Lt, and z must be adjusted by the designer to balance the calculated or estimated values for the total volume in the basin (Vt). The depth (Pt) was increased from 0.6 to 0.7 m to leave room for sediment storage.

#### Calculation steps, for a basin of undefined length

Equation 10, Calculation of sediment storage volume: V2

$$V2 = 4.1 \times 5 \times 5 \div 1.47 = 70 \text{ m}^3$$

Total basin volume = V1 + V2 = 13 m<sup>3</sup> + 70 m<sup>3</sup> = 83 m<sup>3</sup> (or 17 m<sup>3</sup> per hectare of watershed)

Equation 11, Calculation of maximum storage length of basin: lt

$$lt = 0.7 \times 100 \div 0.2 = 350 \text{ m}$$

Equation 12, Calculation of total volume in basin: Vt, depending on values selected for Pt, Lt, and z

$$Vt = 0.6 \times 0.7 \times 350 \div 2 + 1/3 \times 0.7^2 \times 1.5 \times 350 = 159 \text{ m}^3$$

If a ditch that has a width at the floor of 0.6 m, a total depth near the drainage well of 0.7 m, and a side slope of 1:1.5 is used as a storage and sedimentation basin, the length of the flooded ditch during operation will be 350 m, and its storage volume will be 159 m<sup>3</sup>. That basin will have a unit storage volume of 32 m<sup>3</sup>/ha.





### 3.6 Evaluation of trapping efficiency based on the shape of the water storage and sedimentation basin

The sedimentation efficiency of a water storage and sedimentation basin is also affected by its shape. The straighter and more elongated the basin is, or the more obstacles that it contains, the longer the water circulation and sedimentation time will be. Figure 4 provides the values for the hydraulic efficiency coefficient ( $\lambda$ ).

By means of Equations 17 and 18 (Melbourne Water, 2005), it is possible to compare basin performance and calculate the trapped fraction of the target sediments. A trapping efficiency of 100% is rarely achieved, because of turbulence, especially if the objective is to trap fine particles. The most efficient shapes are, in descending order, J, E and G (same coefficient), P, and Q. Basins built in agricultural ditches (shape J) are thus recommended.

The final area of the basin ( $A_f$ ) is calculated by taking into account the mean of the water surface widths at the upstream and downstream ends of the basin, as well as its length.

- If the basin is to be built in a long ditch that has minimal slope and whose upstream end is dry, the final area ( $A_f$ ) is calculated using Equation 15.
- If the length of the basin is to be determined by the designer, and the upstream end of the basin is not dry, the final area ( $A_f$ ) is calculated using Equation 16, and the depth of the basin at the upstream end ( $P'$ ) is calculated using Equation 13.

Equations 15, 16, 17, and 18

Calculation of final area of a basin in a ditch with minimal slope (Equation 15):

$$A_f = \left( \frac{L_t + 2 \times P_t \times z + L_t}{2} \right) \times l_t$$

Calculation of final area of a basin whose length is determined by the designer (Equation 16):

$$A_f = \left( \frac{L_t + 2 \times P_t \times z + L_t + 2 \times P' \times z}{2} \right) \times l_t$$

Calculation of turbulence parameter (Equation 17):

$$n = 1 \div (1 - \lambda)$$

Calculation of basin performance or trapped fraction of target sediments (Equation 18):

$$R = 1 - [1 + 1/n \times V_p \div (Q \div A_f)]^{-n}$$

where

- A<sub>f</sub>:** final area of basin (m<sup>2</sup>)
- L<sub>t</sub>:** final width at floor of basin (m)
- P<sub>t</sub>:** total depth of basin near drainage inlet (m)
- P':** total depth of basin at upstream end (m)
- z:** slope of sides (for 1:1.5, z = 1.5)
- l<sub>t</sub>:** maximum storage length of basin (m)
- n:** turbulence parameter
- λ:** hydraulic efficiency coefficient
- R:** basin performance or trapped fraction of target sediments
- V<sub>p</sub>:** vertical fall velocity of particles (m/s)
- Q:** discharge rate (m<sup>3</sup>/s)

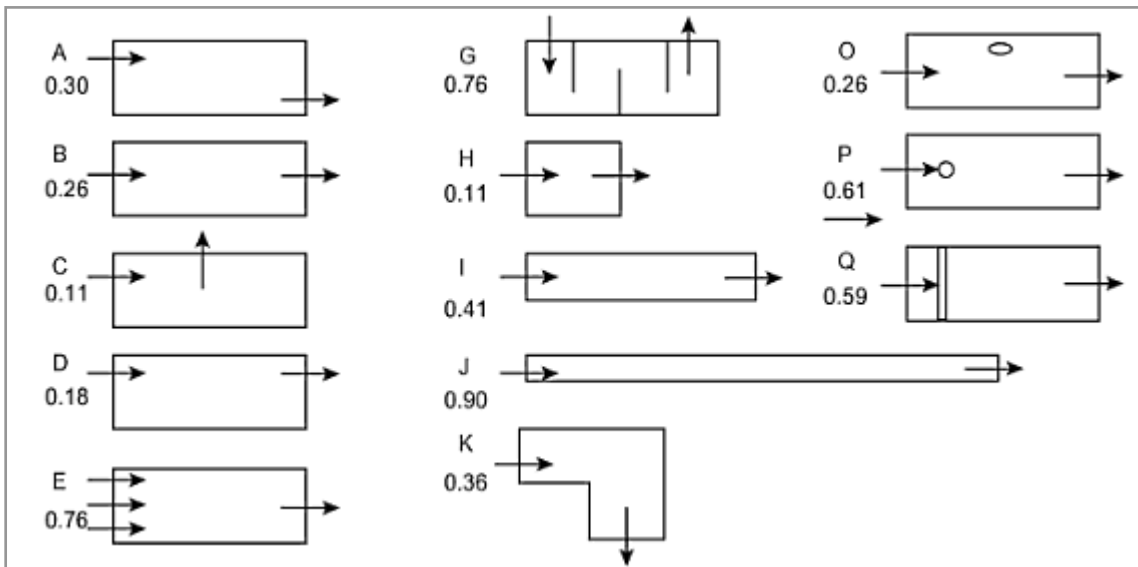

Figure 4: Hydraulic efficiency coefficient ( $\lambda$ ) values for different basin shapes (Melbourne Water, 2005).



### Example of the sizing of a water storage and sedimentation basin

#### Basic data

- Total depth of basin:  $P_t = 0.7$  m
- Final width at floor:  $L_t = 0.6$  m
- Slope of sides: 1:1.5, therefore batter  $z = 1.5$
- Maximum storage length of basin:  $l_t = 350$  m
- Shape of basin: J
- Discharge rate:  $Q = 5\% \times Q_p = 0.006$  m<sup>3</sup>/s
- Fall velocity:  $V_p = 0.000222$  m/s

#### Calculation steps, for a basin of undefined length

Equation 15, Calculation of final basin area: **A<sub>f</sub>**

$$A_f = (0.6 + 2 \times 0.7 \times 1.5 + 0.6) \div 2 \times 350 = 578 \text{ m}^2$$

Equation 17, Calculation of turbulence parameter: **n**

$$n = 1 \div (1 - 0.9) = 10$$

Equation 18, Calculation of basin efficiency: **R**

$$R = 1 - [1 + 1/10 \times 0.000222 \div (0.006 \div 578)]^{-10} = 0.99$$

This elongated basin with a final length of 350 m and an area of 578 m<sup>2</sup> would have a trapping efficiency of 99% for medium silt.



Basin in operation during a high-water event. Source: Victor Savoie (MAPAQ)

## 4. Empirical method for sizing a water storage and sedimentation basin with optimum volume

The calculation method set out above can be used to assess, by means of theoretical sedimentation equations, the minimum volume required for a basin to trap the target suspended particles. A number of studies carried out in the laboratory or the field, summarized in Appendix 1, indicate that the load of sediments and nutrients bound to soil particles is reduced when the storage volume is larger. It should be noted that this tendency is not observed when most of the nutrients present are in soluble form (Tiessen, 2011).

To achieve high sedimentation efficiency while keeping the storage volume within acceptable limits, the recommendation is to manage the runoff from 90% of rainfall events on an annual basis (Schueler, 2008; Papa et al., 1999; Urbonas, 1999). Those rainfall events, for which the maximum depths are 20 to 25 mm according to Quebec weather data and which are presented in Table 5, have runoff rates ranging from 0.15 to 0.25 in Quebec or on the U.S. east coast (Table 6).

Table 5: Rainfall depths corresponding to 90% of rainfall events on an annual basis (adapted from Rivard and Rinfret, 2012).

Weather station	Period analyzed	Rainfall depth (mm)
Quebec City	ND	26
Granby Shawinigan	1968-2000	25
Sherbrooke	1962-1995	24
Drummondville Lennoxville	1967-2000 1960-1995	23
Montréal Victoriaville	ND 1963-1984	22
Ormstown St-Hubert Ste-Clothilde Ste-Madeleine	1963-2000 1964-1999 1967-1990 1979-2000	21



Table 6: Unit volumes and runoff coefficients for rainfall depths of 20 to 25 mm (Schueler, 2008; Guillou, 2012; Chrétien, 2012b).

Site	Area (ha)	Number of events analyzed	Mean runoff coefficient	Mean unit runoff volume (m <sup>3</sup> /ha)	Location
Cloutier	445	9	0.16	36	Montérégie-Ouest, Quebec
Berna	7.2	7	0.16	38	
Landry	7.1	6	0.22	51	
St-Samuel*	23.1	35	0.19	44	Centre-du-Québec, Quebec
Disturbed permeable soil			0.15 to 0.25		Maryland

\*Analysis of rainfall depths of 10 to 25 mm.

The unit water storage volume required is in the order of 32 to 65 m<sup>3</sup> per hectare in the watershed, depending on the runoff rate and the location of the site (21 mm × 0.15 = 3.2 mm or 32 m<sup>3</sup>/ha, and 25 mm × 0.25 = 6.5 mm or 65 m<sup>3</sup>/ha), values that are comparable to those measured in Table 6. With this approach, good levels of sediment and nutrient trapping can be achieved, as indicated in Appendix 1, without the need to target a specific soil particle diameter. To this water volume required to promote sedimentation must be added the volume required for sediment storage, as indicated in Section 3.5.

If the objective is to reduce peak stream flows and increase sedimentation, the installation of a wet pond can be considered. Able to store a large volume of water (100 to 250 m<sup>3</sup> per hectare in the watershed), wet ponds hold a permanent pool of water, have a unit volume in the order of 50 m<sup>3</sup>/ha, and slow down runoff more effectively (Chrétien, 2012a). More information on wet ponds is available in the report by Rivard and Rinfret (2012). For reference purposes, the design standards for temporary runoff storage basins in Ontario (water and sediment control basins, or WASCoBs) are based on an unit volume ranging from 50 to 150 m<sup>3</sup>/ha, to which the volume required for sediment accumulation is added (OMAFRA, 2008).

### Example of the sizing of a water storage and sedimentation basin

#### Basic data

- Calculation of minimum water volume in basin:  
V1 = 13 m<sup>3</sup> (or 3 m<sup>3</sup>/ha)
- Calculation of sediment storage volume:  
V2 = 70 m<sup>3</sup>
- Total recommended basin volume:  
83 m<sup>3</sup> (or 17 m<sup>3</sup>/ha)
- Maximum storage length of basin:  
lt = 350 m
- Total basin volume:  
Vt = 159 m<sup>3</sup>, depending on ditch slope and depth

The effective runoff storage volume will be 159 m<sup>3</sup> (or 32 m<sup>3</sup>/ha) when the basin is put into operation and will drop to 89 m<sup>3</sup> (or 18 m<sup>3</sup>/ha) 5 yr later, based on theoretical filling with sediments. That storage volume will allow most of the medium silt load to be trapped. Sedimentation of a wider range of soil particles, including fine silt, would be achieved if a water storage volume of 150 m<sup>3</sup> (or 30 m<sup>3</sup>/ha) were to be maintained at all times, in addition to the planned volume for sediment accumulation, namely 70 m<sup>3</sup>. The total basin volume, 220 m<sup>3</sup>, could be achieved by widening the ditch floor, digging the ditch deeper, or reducing the slope of the sides.



## 5. Size of the emergency spillway and discharge pipe

Some runoff events can exceed the water discharge capacity through the perforations in the drainage inlet. Provisions must therefore be made for other options for discharging the water without causing erosion.

A water storage and sedimentation basin should ideally be equipped with an emergency spillway at the downstream end and be designed to discharge the drainage basin's 10-yr peak flow in the event of significantly high water levels. If the runoff is concentrated at the basin inlet, another rock chute spillway may be required upstream. The floor of the emergency spillway must be located more than 0.20 m below the surface of the surrounding field to allow water to be discharged while limiting overflow. Installation details are provided in the fact sheet entitled Rock Chute Spillways (Lamarre, 2009).

**When an emergency rock chute spillway is used, the discharge pipe and the upper portion of the drainage inlet will have a capacity ranging from 10% to 30% of the 10-yr peak flow, for rain of equal duration to the concentration time. If there is no emergency spillway, the capacity of the discharge pipe and the upper portion of the drainage well will need to be 100% of the 10-yr peak flow.**

For reference purposes, Table 7 sets out recommended pipe diameters. This table can be used under the following conditions:

- The peak flow has been calculated using the rational method combined with the concentration time in accordance with Mockus, for a field under annual crops and conventional tillage.
- Use of the table is reserved for sites with minimal slope (<1% upstream and downstream of the drainage inlet) and with little risk of erosion.
- The structure will be combined with a rock chute spillway.
- The minimum slope of the pipe is 0.2%.
- If a corrugated drain with perforations is used, the appropriateness of using a filter must be assessed.

For other situations, it is recommended that the pipe flow rate be determined using a calculation suited to the actual site conditions.

A metal grate will need to be installed on the upper portion of the drainage inlet to prevent clogging with crop residues. The grate can be a piece of wire mesh fencing (12-gauge)

or a cylindrical enclosure with vertical walls. The top of the drainage inlet's perforated column must be at least 0.2 m lower than the floor of the emergency spillway or the surrounding ground.

**Table 7:** Discharge pipe diameters based on the area of the discharge basin (Savoie, V., Arel, A. 2010, MAPAQ Nicolet).

Diameter of corrugated pipe (mm)	Low-percolation soil <sup>1</sup> (clay and/or silt, compact, poorly structured) (ha)	Medium-percolation soil <sup>2</sup> (sand and/or structured clay) (ha)
100 <sup>3</sup>	1 to 1.5	1 to 2
150	1.5 to 3	2 to 5
200	3 to 7	5 to 10
250	7 to 10	

<sup>1</sup> Runoff coefficient of 0.45.

<sup>2</sup> Runoff coefficient of 0.30.

<sup>3</sup> Higher risk of blockage because of the size of the pipe. Depending on the situation, the designer can use a 150-mm-diameter pipe by creating a restriction at the inlet.



Grate installed on a drainage inlet.

Source: Alain Gagnon (MAPAQ)

### Example of the sizing of a water storage and sedimentation basin

#### Basic data

- *Watershed with minimal slope:* A = 5 ha
- *Low-percolation soil*

The main pipe and the drainage inlet will be 200 mm in diameter, according to Table 7. An emergency rock chute spillway will be built downstream to discharge the 10-yr peak flow without causing erosion.





## 6. Size and distribution of perforations

The discharge rate through the perforations in the vertical column of the drainage inlet will correspond to 5% of the watershed's 10-yr peak flow, for rain of duration equal to the concentration time, as indicated in Section 3.2. One third of the perforations will be made in the lower two thirds of the column, and the remaining two thirds of the perforations will be made in the upper third of the column. Table 8 specifies the number of perforations required, depending on the perforation diameter selected by the designer. Figure 5 summarizes all the sizing recommendations.

### Example of the sizing of a water storage and sedimentation basin

#### Basic data

- 10-yr peak flow:  $Q_p = 0.12 \text{ m}^3/\text{s}$
- Discharge rate:  $Q = 5\% \times Q_p = 0.006 \text{ m}^3/\text{s}$

According to Table 8, the vertical column of the drainage inlet will have eight 1-in.-diameter perforations, which will be distributed as follows: five in the upper third of the drainage inlet column, and three in the lower two thirds of the column.

Table 8: Number of perforations in the drainage inlet column (Savoie, V., Arel, A. 2010, MAPAQ)

10-yr flow rate ( $\text{m}^3/\text{s}$ )	5% of flow rate ( $\text{m}^3/\text{s}$ )	Number of perforations depending on their diameter		
		$\frac{3}{4}$ in.	1 in.	1 $\frac{1}{2}$ in.
0.03	0.0015	4	2	1
0.05	0.0025	6	3	1
0.07	0.0035	8	5	2
0.09	0.0045	10	6	3
0.11	0.0055	12	7	3
0.12	0.006	14	8	3
0.14	0.007	16	10	4
0.18	0.009	20	12	5
0.2	0.01	22	13	6
0.22	0.011	25	15	6
0.24	0.012	27	16	7
0.26	0.013	29	18	7





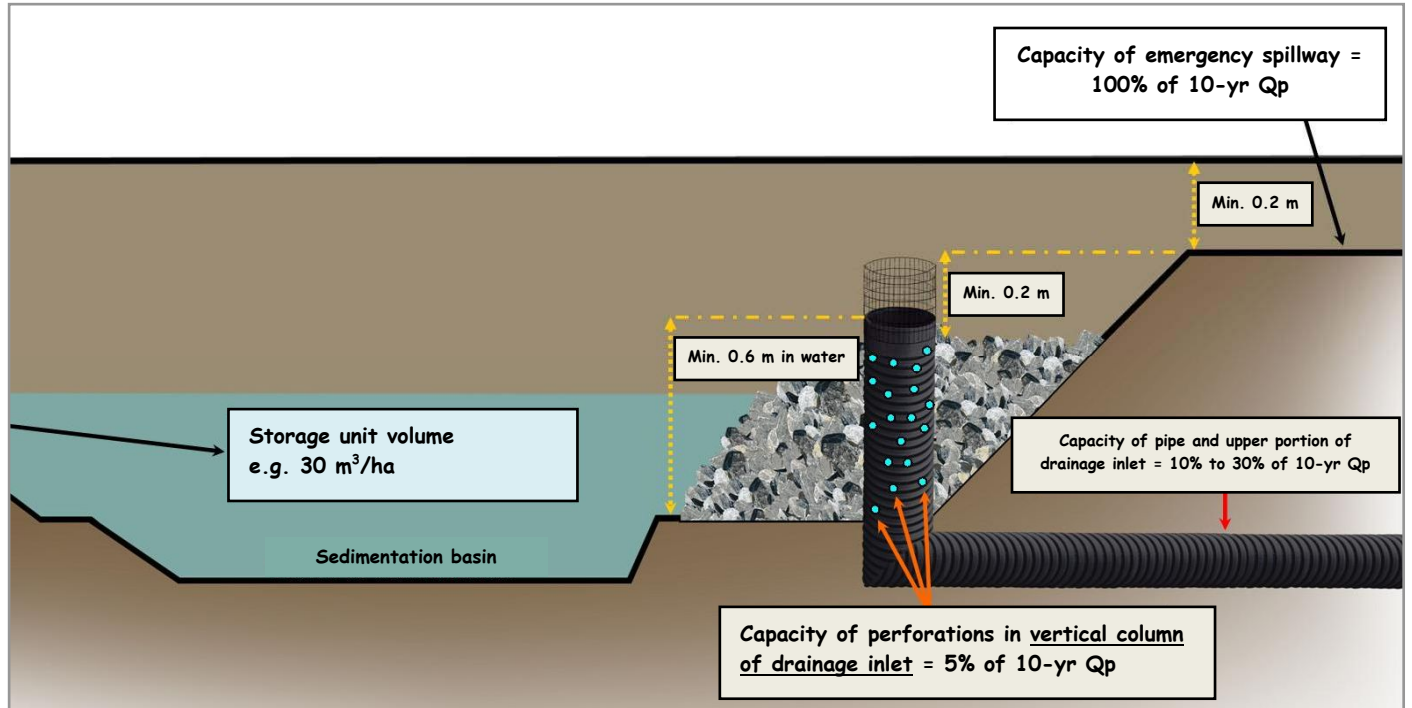

Figure 5: General overview of the sizing of a combined discharge structure (drainage inlet and rock chute spillway).

## 7. Maintenance

Ideally, the floor and sides of a water storage and sedimentation basin should be planted with herbaceous vegetation as soon as construction is finished and be kept under plant cover throughout its useful life, in order to stabilize the sides and improve the trapping of sediments and pesticides (Moore et al., 2011).

The basin should be inspected after each high-water event to clear residues off the drainage well grate and check whether the level of sediment accumulation is reducing the basin's trapping efficiency. The cleanout frequency can vary from one to several years depending on the extent of soil erosion in the watershed. The most critical situation occurs where the ground is sloped and under annual crops and conventional tillage.





## References

- Chrétien, F. 2012a. Étangs épurateurs et régulateurs de l'eau en milieu agricole. Canadian Water Resources Association.
- Chrétien, F. 2012b. Impact des étangs épurateurs sur la qualité de l'eau. Personal communication.
- Goldman, S.J., Jackson, K., Bursztynsky, T.A. 1986. Erosion and Sediment Control Handbook. McGraw-Hill. 454 p.
- Guillou, M. 2012. Hydrologie à l'échelle de parcelles agricoles en Montérégie. Rapport d'étape. MAPAQ.
- Lamarre, G. 2009. Rock Chute Spillways. Fact sheet. AAFC, MAPAQ.
- Mailhot, A., Talbot, G. 2011. Mise à jour des estimateurs Intensité-Durée-Fréquence (IDF) pour le Sud-Québec. Tome II. INRS. Rapport R-1260. 231 p.
- MAPAQ, 1990. Normes de conception et d'exécution pour les travaux de conservation et gestion du sol et de l'eau.
- MDDEP, 1997. Guide d'aménagement des lieux d'élimination de neige et mise en oeuvre du Règlement sur les lieux d'élimination de neige.  
[http://www.mddep.gouv.qc.ca/matieres/neiges\\_usees/annexe\\_e.htm](http://www.mddep.gouv.qc.ca/matieres/neiges_usees/annexe_e.htm)  
<http://collections.banq.qc.ca/ark:/52327/bs43030>
- Melbourne Water, 2005. Water Sensitive Urban Design Engineering Procedures: Stormwater.
- Moore, M.T., Denton, D.L., Cooper, C.M., Wrynski, J., Miller, J.L., Werner, I., Horner, G., Crane, D., Holcomb, D.B., Huddleston, G.M. 2011. Use of vegetated agricultural drainage ditches to decrease pesticide transport from tomato and alfalfa fields in California, USA. Environmental Toxicology and Chemistry. 30:1044-1049.
- Musy, A., Soutter, M. 1991. Physique du sol. Presses polytechniques et universitaires romandes.
- OMAFRA, 2008. Agricultural Erosion Control Structures. Publication 832. 273 p.
- Papa, F., Adams, B.J., Guo, Y. 1999. Detention time selection for stormwater quality control ponds. Canadian Journal of Civil Engineering. 26:72-82.
- Rivard, G., Rinfret, L.-A. 2012. Design of Stormwater Treatment and Flow Regulation Ponds. Report for Agriculture and Agri-Food Canada. 62 p.
- Schueler, T. 2008. Technical Support for the Bay-Wide Runoff Reduction Method. Chesapeake Stormwater Network.
- Stampfli, N., Beaulieu, R., Breune, I., Guillou, M. 2007a. Evaluation of Peak Flows for Small Agricultural Drainage Basins in Quebec. Fact sheet. AAFC, MAPAQ.
- Stampfli, N., Beaulieu, R., Breune, I., Guillou, M. 2007b. Inlet and Drainage Wells. Fact sheet. AAFC, MAPAQ.
- Tiessen, K.H.D., Elliott, J.A., Stainton, M., Yarotski, J., Flaten, D.N., Lobb, D.A. 2011. The effectiveness of small-scale headwater storage dams and reservoirs on stream water quality and quantity in the Canadian Prairies. Journal of Soil and Water Conservation. 66:158-171.
- Urbanas, B. 1999. Assessment of stormwater best management practice effectiveness.
- USACE, 2010. Hydrologic Modeling System. HEC-HMS User's Manual. Version 3.5. 316 p.  
[http://www.hec.usace.army.mil/software/hec-hms/documentation/HEC-HMS\\_Users\\_Manual\\_3.5.pdf](http://www.hec.usace.army.mil/software/hec-hms/documentation/HEC-HMS_Users_Manual_3.5.pdf)
- Winer, R. 2000. National Pollutant Removal Performance Database for Stormwater Treatment Practices. 2nd edition. EPA.

## Appendix 1: Trapping Efficiency of Basins by Unit Storage Volume

Location and source(s)	Pond type	Unit storage volume (m <sup>3</sup> /ha)	Effect on annual load or annual nutrient concentration		
			Total N	Total P	Suspended matter
Ontario Papa, 1999	Dry	50 <sup>1</sup> 100			↓ 56% ↓ 66%
Schueler, 2008; Urbonas, 1999	Dry	37 to 62 <sup>1</sup>	↓ 10% to 20%	↓ 10% to 20%	↓ 50% to 70%
St-Samuel, Quebec <sup>2</sup> Chrétien, 2012b	Wet	48 94 during high-water events	↓ 45%	↓ 51%	↓ 52%
US database Winer, 2000	Wet	250	↓ 31%	↓ 52%	↓ 80%
Manitoba <sup>3</sup> Tiessen, 2011	Dry	217	↓ 20%	↓ 9%	↓ 66%
	Wet	292	↓ 15%	↓ 12%	↓ 77%

<sup>1</sup> Corresponding to the management of 25 mm rain.

<sup>2</sup> 2009-2012 results, follow-up from April to November, 13 events.

<sup>3</sup> Small reduction in phosphorus load by basins, because load was made up of 80% soluble phosphorus.

**Text:** Mikael Guillou, MAPAQ

**Sketches and graphics:** Johannie Goulet, MAPAQ

**Revision:** *MAPAQ:* Alain Gagnon, Gaétan Lefebvre, Pierre Luc Lizotte, Ghislain Poisson, Régis Potvin, Victor Savoie  
*Agriculture and Agri-Food Canada:* Isabelle Breune, François Chrétien

May 2013