

GATES, CATTLEGUARDS and PASSAGEWAYS

This factsheet looks at various options for allowing passage through fences for livestock, wildlife and people.

GENERAL REQUIREMENTS

A dictionary definition of a gate is “an opening into an enclosure”. A gate is required to allow movement across a fence line that has been erected to stop such movement. A gate may regulate movement of:

- machinery and livestock - typical hinged sections of fence
- machinery only - a cattle guard
- livestock only - corral handling, sorting and separation of livestock
- people only - various stiles or passageways
- water only - various floodgates
- wildlife - one direction gates

An effective gate must allow passage while having the following features:

- convenient and effective location
- wide enough (to allow passage of equipment)
- high enough (usually as high as the fence)
- if hinged, free from obstacles to open fully
- if latched, convenient yet stock proof from accidental opening
- durable
- cost effective

Generally, the more often a gate is used the better quality it should be. Gates may be constructed of metal, wire, wood or combinations of these materials. They may be electrified in the case of electric fences. They may be hinged or ‘slip-wire’, hand latched or automatically latched. They may have adjustable mounting for deep snow locations. These and other options are covered in the following discussions.

Locating Gates

Roads, pathways, streams or other reasons may determine gate location with little choice available. In these cases, choose a suitable design from the following layouts. However, if the gate location is not certain, consider the following:

Livestock generally will move easier through a gate located at or near a fence corner rather than one placed along the fence.

The movement of machinery will require a safe distance of straight road on either side of the gate. If a turn is required, the gate may have to be made wider than standard.

Gates on boundary fencelines on busy roads should be set back from the fenceline a distance sufficient to allow vehicles a safe pull off distance prior to reaching the gate, as in Figure 1, below. This distance should accommodate the longest truck or tractor/implement combination on the farm.

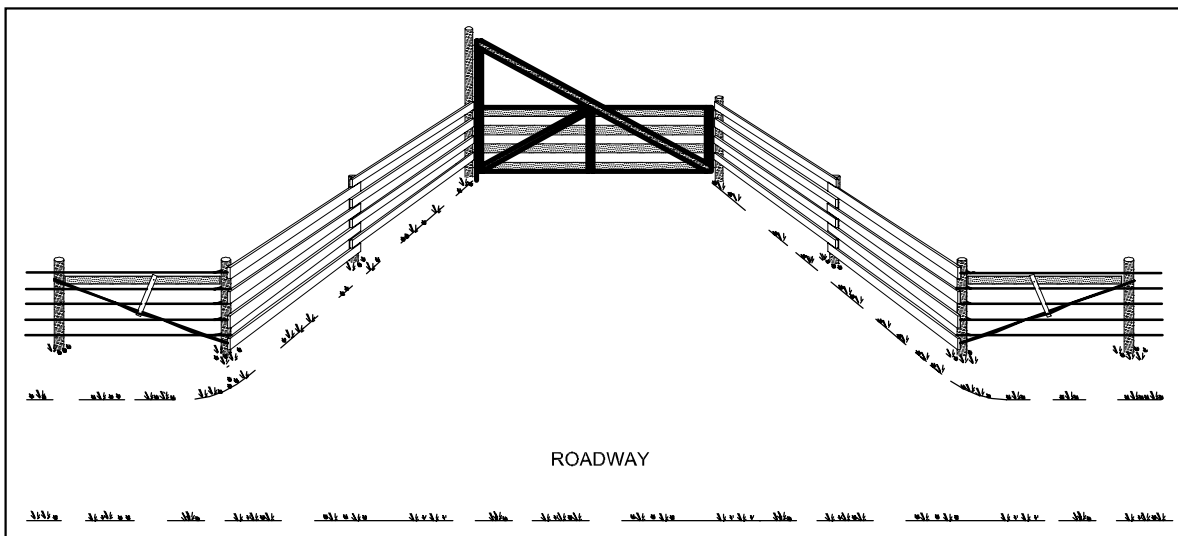

Figure 1

Gate Set Back From a Roadway

Gate Hinges

Gate hinges vary from homemade to purchased. The bottom of the gate hinge post may simply be pinned into a base of wood, rock or concrete with the upper end boxed into the fence post. Or the gate may be hung on a suitable fence end post with steel hinges. Hinge choice depends to a large extent on the weight of the gate. All-wood gates are more difficult to support than lighter steel, wire or aluminum gates. See Figure 5 for estimated weights of typical wood gates.

If a gate is to swing 180° back onto the fence, the hinge must be located offset to that side of the hinge post as shown in Figure 2, below. The gate however will not open as wide in the reverse direction.

As well as hinge design, the fence post will be affected by the weight of the gate. If standard fence end posts are used, gate weight must be limited. A larger post set deeper with additional bracing will be required for heavy gates. Standard fence brace end posts should be supported by using a second brace wire as discussed in [Factsheet 307.220-1](#). Over-length end posts can be supported using a cross support or a diagonal pole down to a fence line post. Some gate mounting and hinge options are shown in Figure 3, page 4.

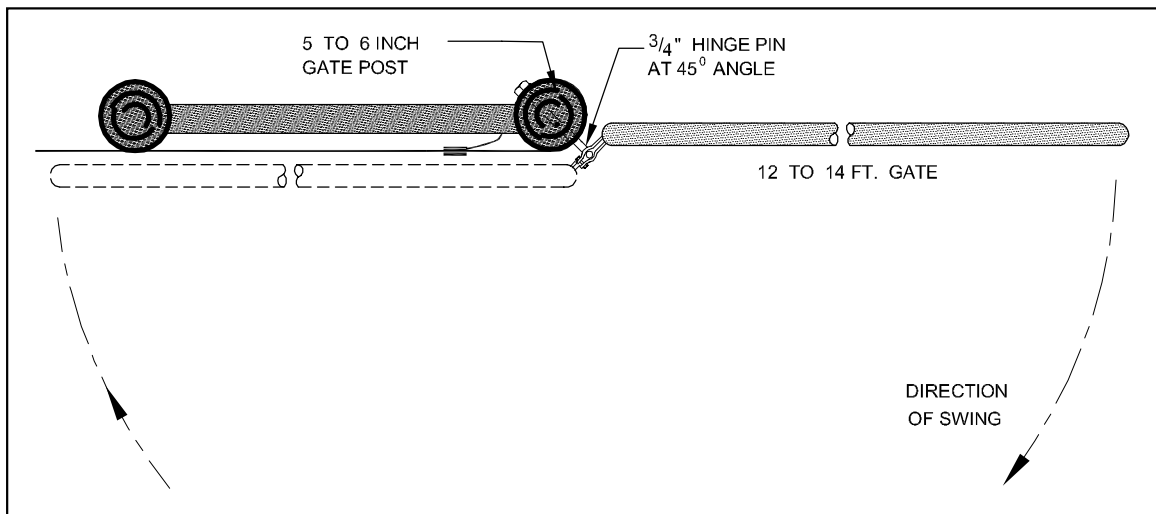

Figure 2

Offset Hinge (full one-way swing)

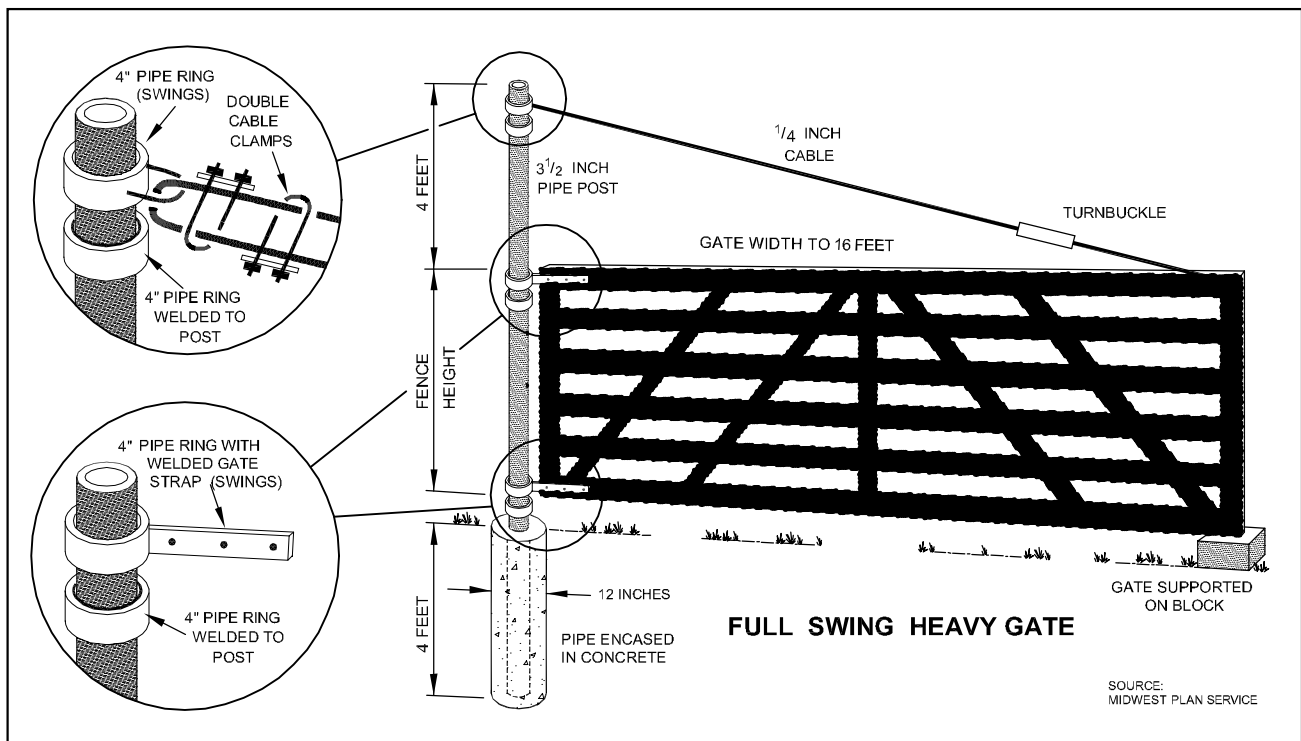
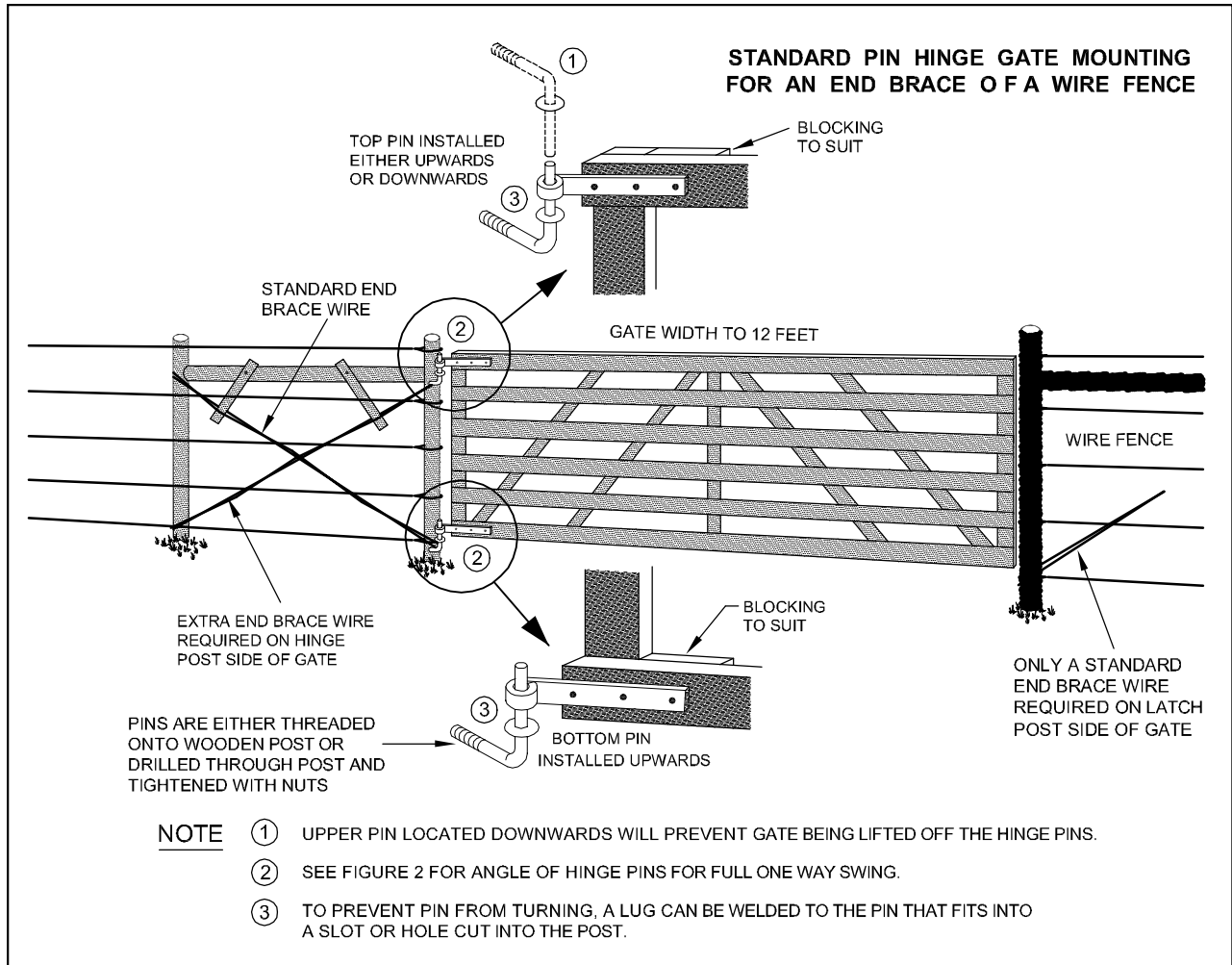

Figure 3

Gate Mounting and Hinge Options

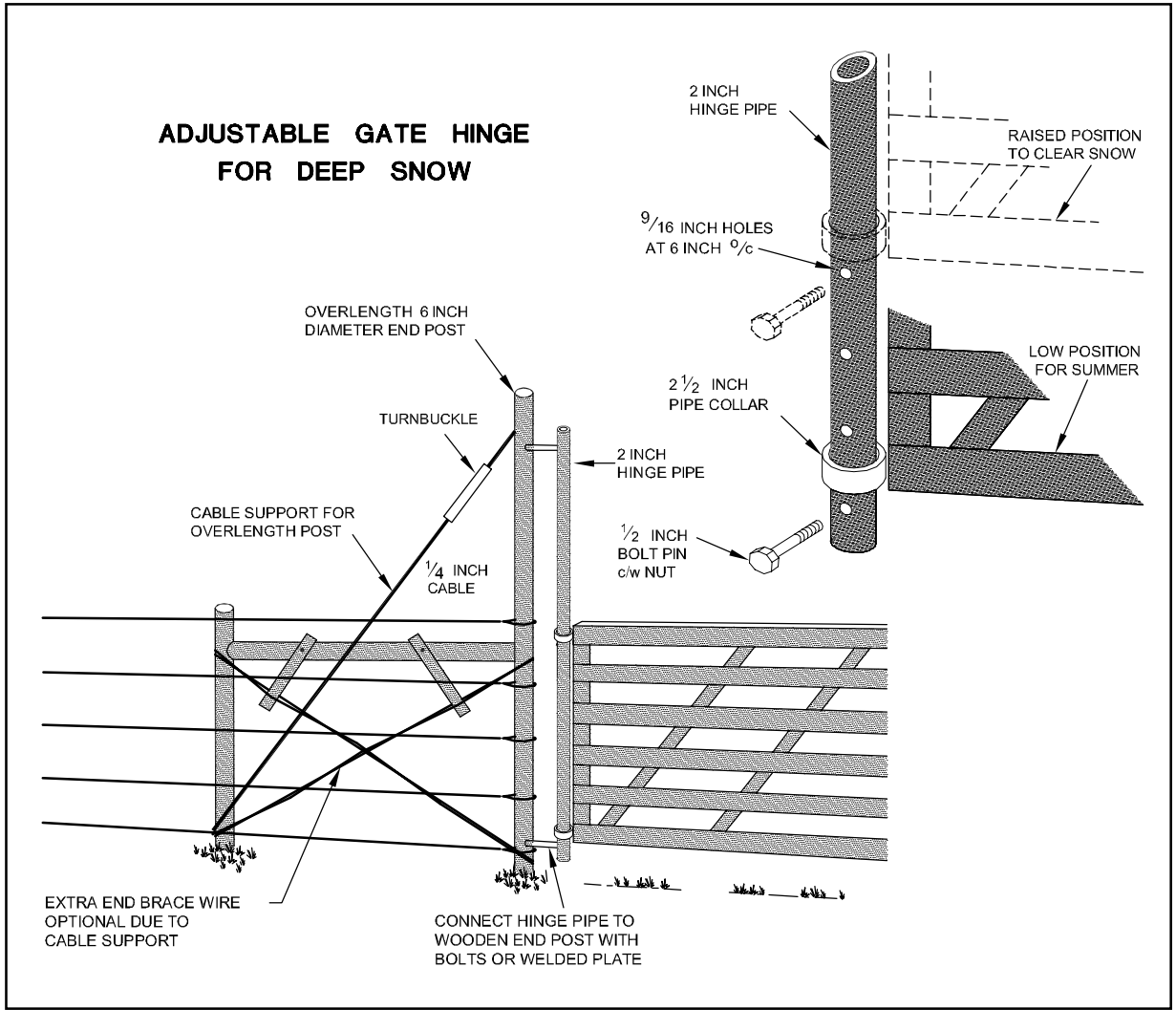

Figure 3 (continued)

Gate Mounting and Hinge Options

Gate Latches

There are as many latch designs used as there are gates on farms. In many cases they are home-built of materials at hand. Successful latches are convenient to use, retain the gate in position and, where required, are livestock proof. Examples are shown in Figure 4, below.

SLIP WIRE GATE LATCHES

WIRE LOOP WITH LEVER ASSIST

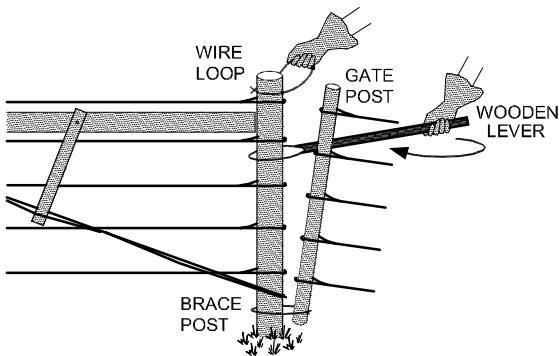

" OVER CENTRE " LATCH

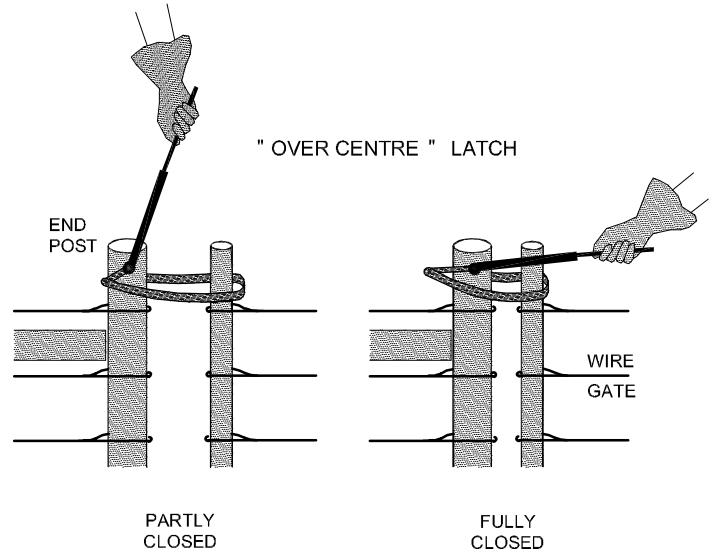

SWING GATES

SLIDING ROD LATCH

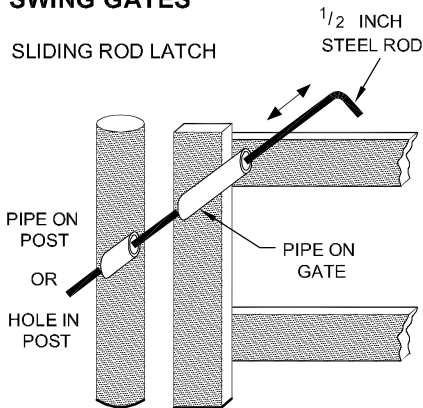

CHAIN AND HOOK LATCH

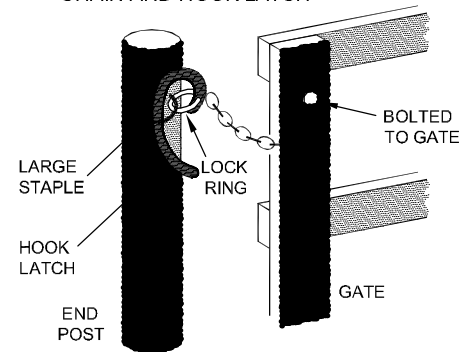

SLIDING BOARD LATCH

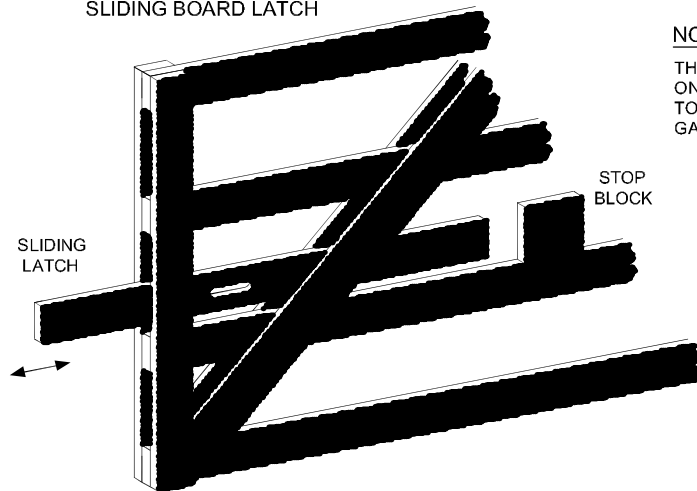

NOTE

THE LOCK RING CATCHES ON THE POST STAPLE TO PREVENT ACCIDENTAL GATE OPENING.

Figure 4

Gate Latches

STANDARD GATES

Wood Gates

Very simple all wood gates are possible on some fences. A panel of a wood rail fence can be built so the rails slide away for access, as shown in Figure 5, page 9. Or a snake rail fence can be crossed by simply opening up panels and re-closing after passing. Neither of these would be as convenient as a hinged gate.

Some common wood hinged gates are shown in Figure 5, below. These designs use either round rails or sawn boards and are often seen in cattle handling facilities or corrals.

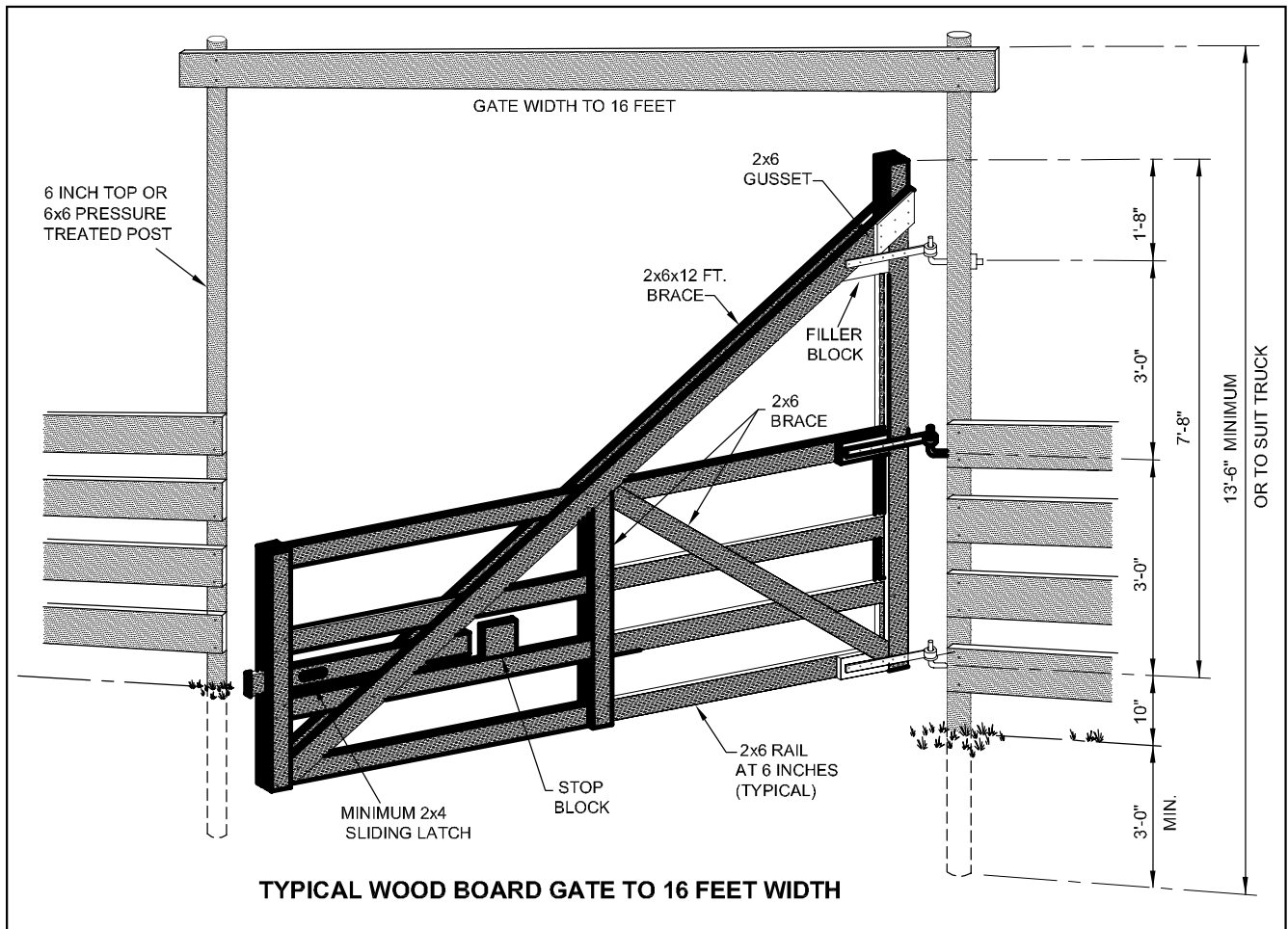

Figure 5

Wood Gates

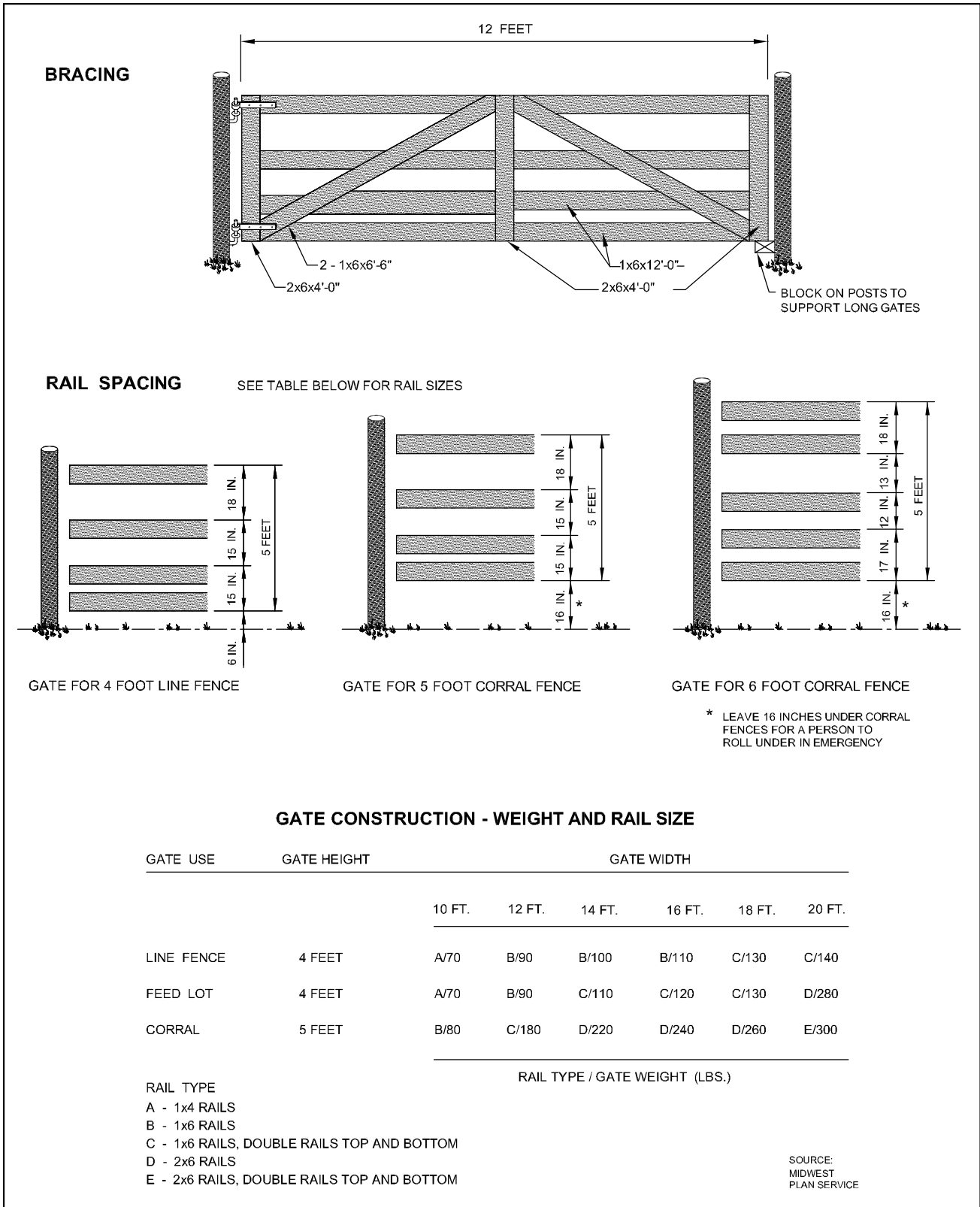

Figure 5 (continued)

Wood Gates

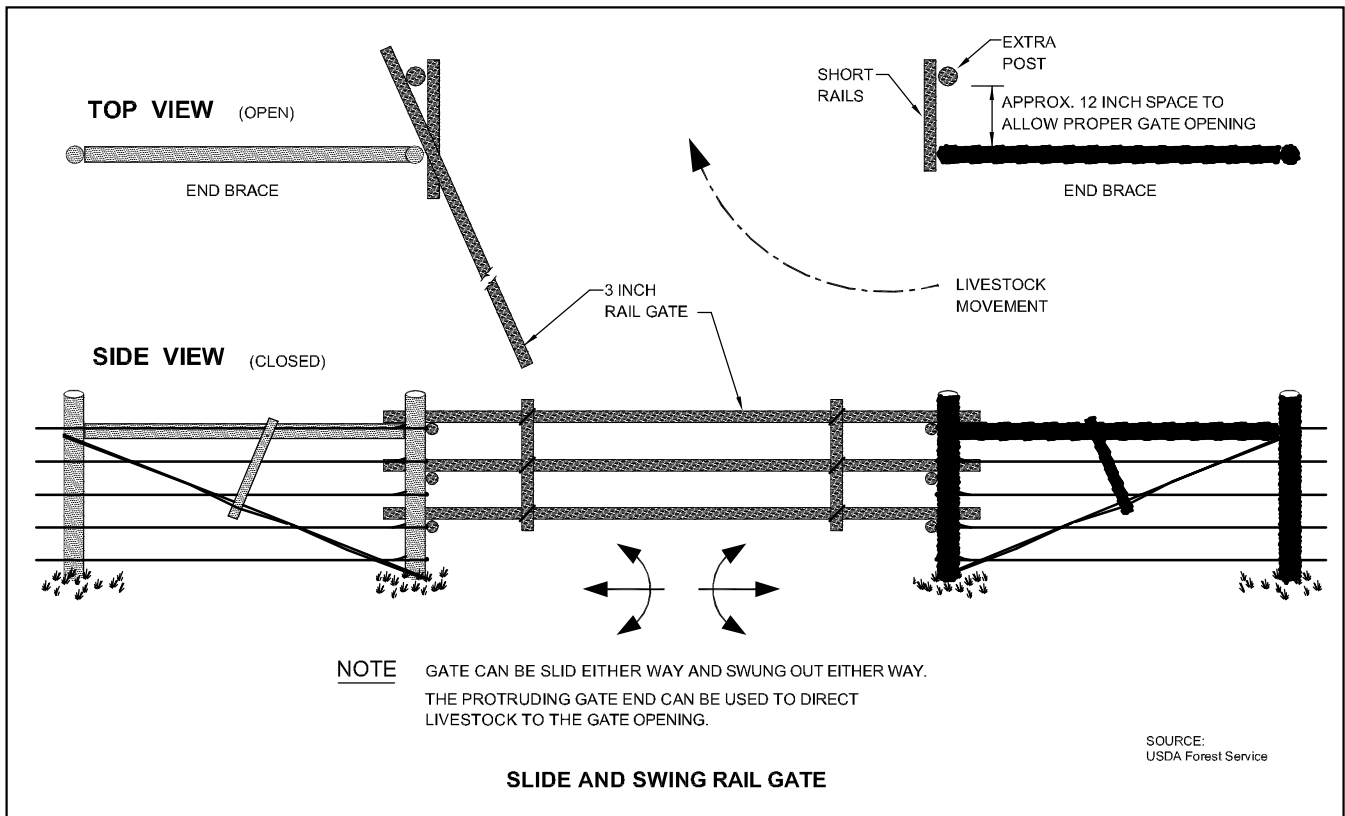
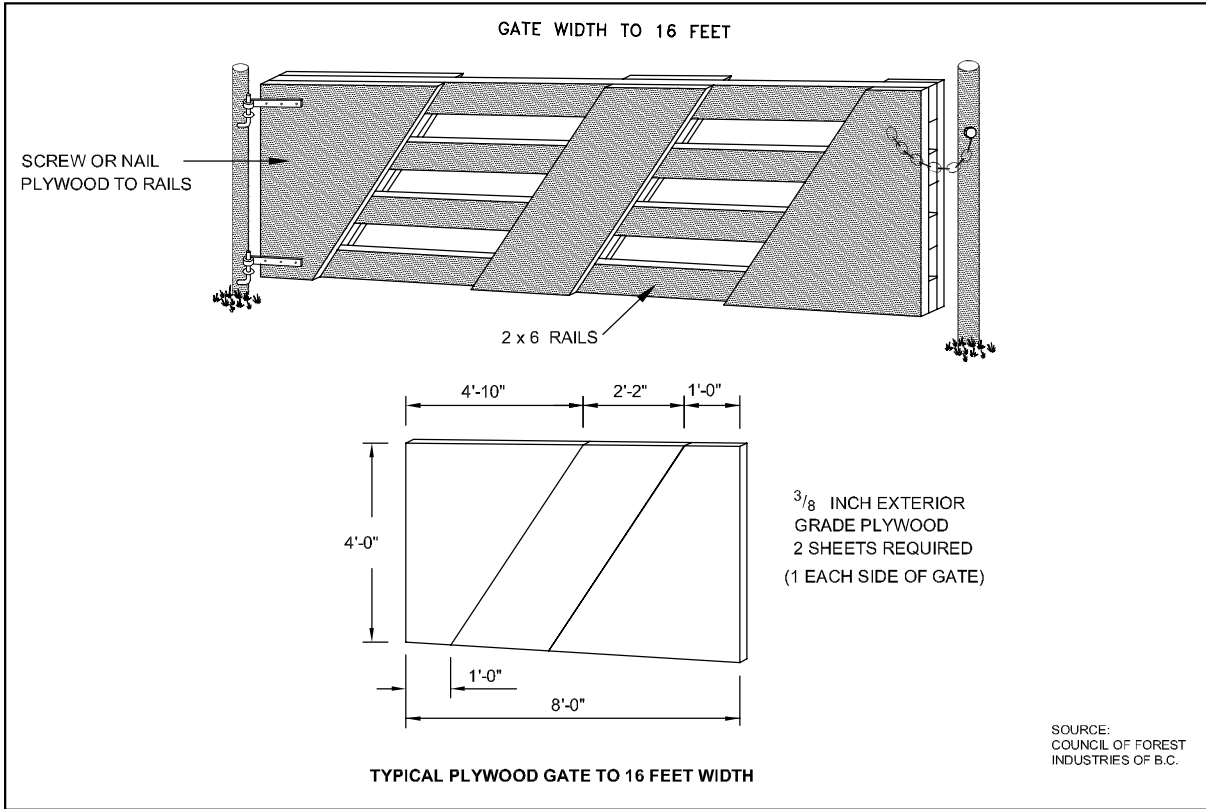

Figure 5 (continued)

Wood Gates

Wire Gates

Many farm gates are constructed using the same wire as used for the fence, i.e., barbed wire gates in barbed wire fences, woven wire in woven wire fences, etc. Very simple, strand wire gates have no frame, only wire and a few wooden uprights. These “slip-wire” gates are low cost but tangle very easy and should only be selected for infrequently used gates.

More substantial wire gates have frames of wood or steel that are used to support the wire and are hung on posts similar to wood gates. Because these wire gates are lighter than all wood gates they are often preferred for long spans. Whatever style of wire gate is used, it must be sufficient to match the requirements of the fence.

Hinged Wire Gate

An alternate to a “slip-wire” gate is a simple hinged wire gate. Two uprights on each end of the gate are connected by a rigid diagonal bolted to the bottom of the hinge post upright and the center of the latch post upright. This allows the weight of the gate to pull the wire strands tight. This frame can be constructed of $\frac{3}{4}$ or 1 inch pipe with welded bolting tabs as in Figure 6, below.

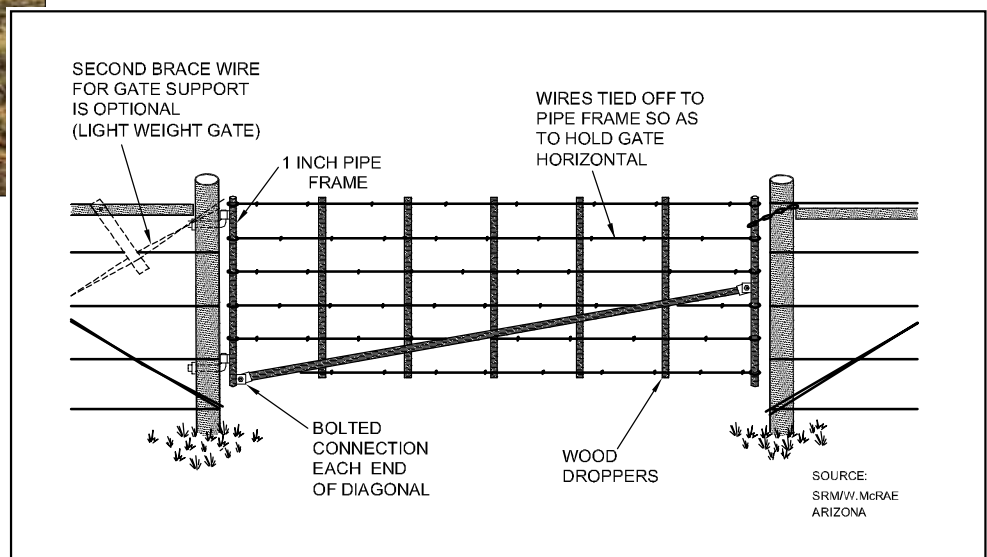

Figure 6

Hinged Wire Gate

Farm-Built Woven Wire Gate

Woven wire fences will often require woven wire gates. These can be purchased commercially or farm built. The gate shown in Figure 7, page 11, is built with a steel frame and a means of tensioning the woven wire.

Metal Gates

If a producer wishes to purchase a farm gate, all-metal gates of steel or aluminum are often chosen. As with wire gates, the metal gates are lighter than all-wood gates of the same span and are hung using similar hinges.

Formed aluminum gates are very light and from the standpoint of weathering, they should last indefinitely. However their strength may not compare favorably to steel or wood gates when exposed to livestock pressure or damage from farm machinery. Figure 8, page 11, is a typical formed metal gate.

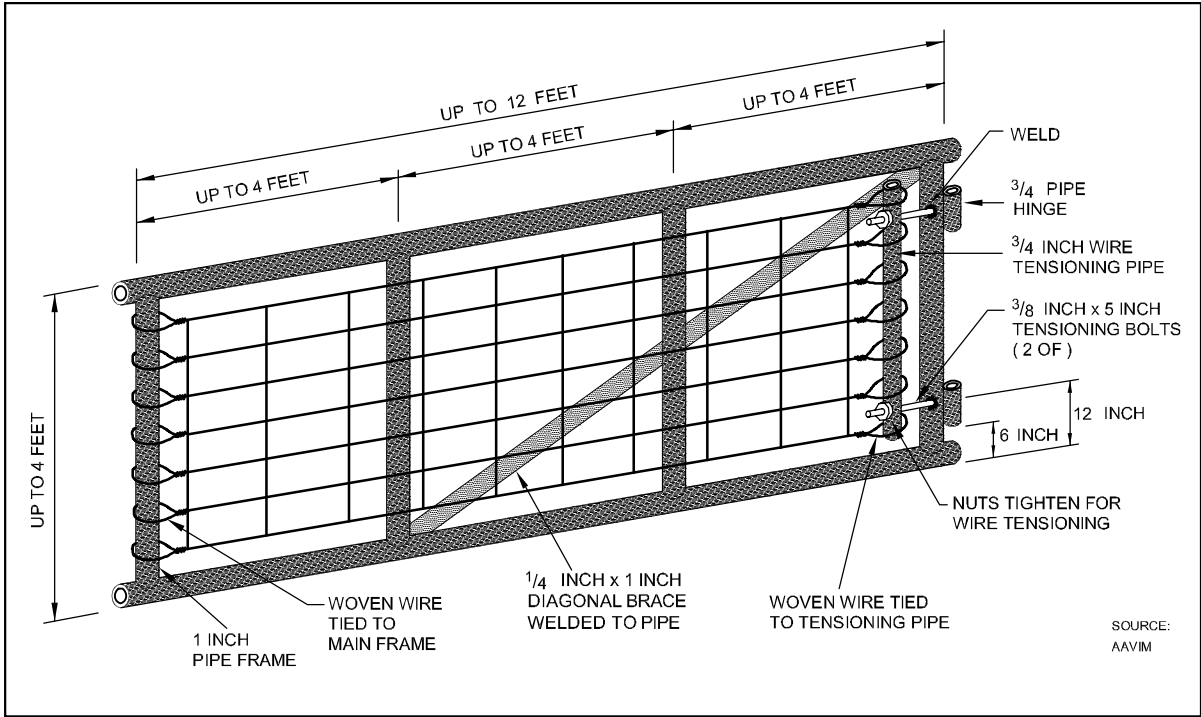

Figure 7 Farm-Built Woven Wire Gate

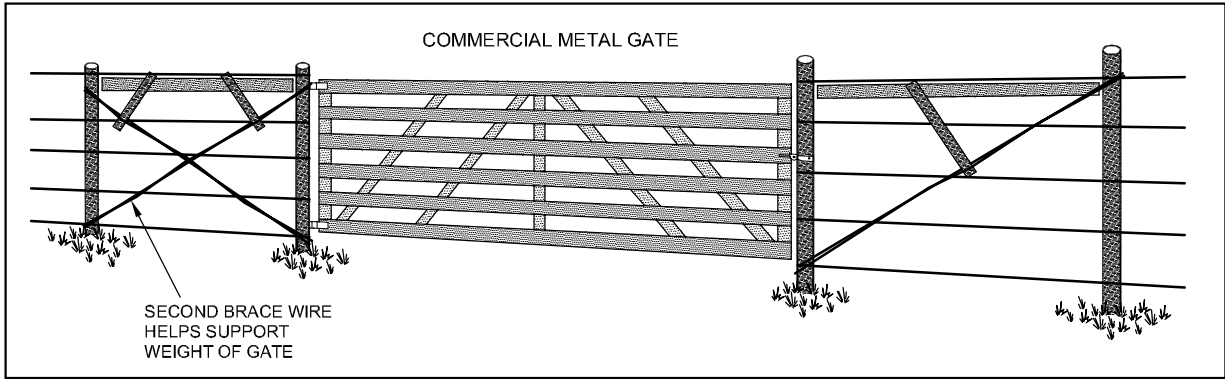

Figure 8 Metal Gate

Electric Gates

Gates in electric fences may be electrified to ensure the effectiveness of the fence but combinations of electric fence and standard gates are also used. In either case, energy from the fence controller must be wired past the gate, either over the gate or under it (buried). Wider gate openings may be required to ensure livestock will pass through easily.

Electric Hook Gate

This is the simplest electric gate and is used in a one to three strand fence where infrequent passage is required. It consists of an insulated handle with a spring loaded hook on one end with the other end wired to the gate wire. By gripping the handle, the gate wire is pulled tight and hooked onto a wire loop on the gate post. This loop should be on the supply side of the electric fence. On closing, the circuit is complete and the gate is electrified. When the handle is unhooked the gate is opened and so is the circuit. As the opened gate is not electrified, it may be laid on the ground without shorting the fence. The fence beyond the gate is not electrified when the gate is opened. See Figure 9, below.

Electric Fence / Standard Gate

In many cases, a standard gate of wood, wire or metal will perform adequately in an electric fence and may be more convenient to use. If required, electric wire(s) may be placed on the gate. Figure 10, page 13, shows two methods of installing standard gates in an electric fence and routing the wire across the gate opening. Refer to [Factsheet 307.300-1](#) (Figure 8) for wiring detail.

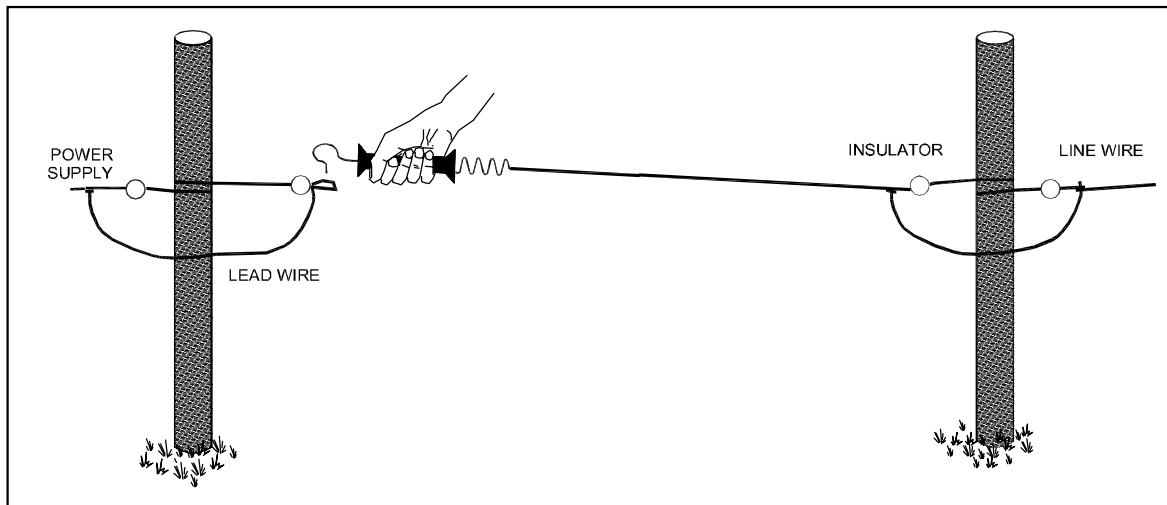

Figure 9

Electric Hook Gate

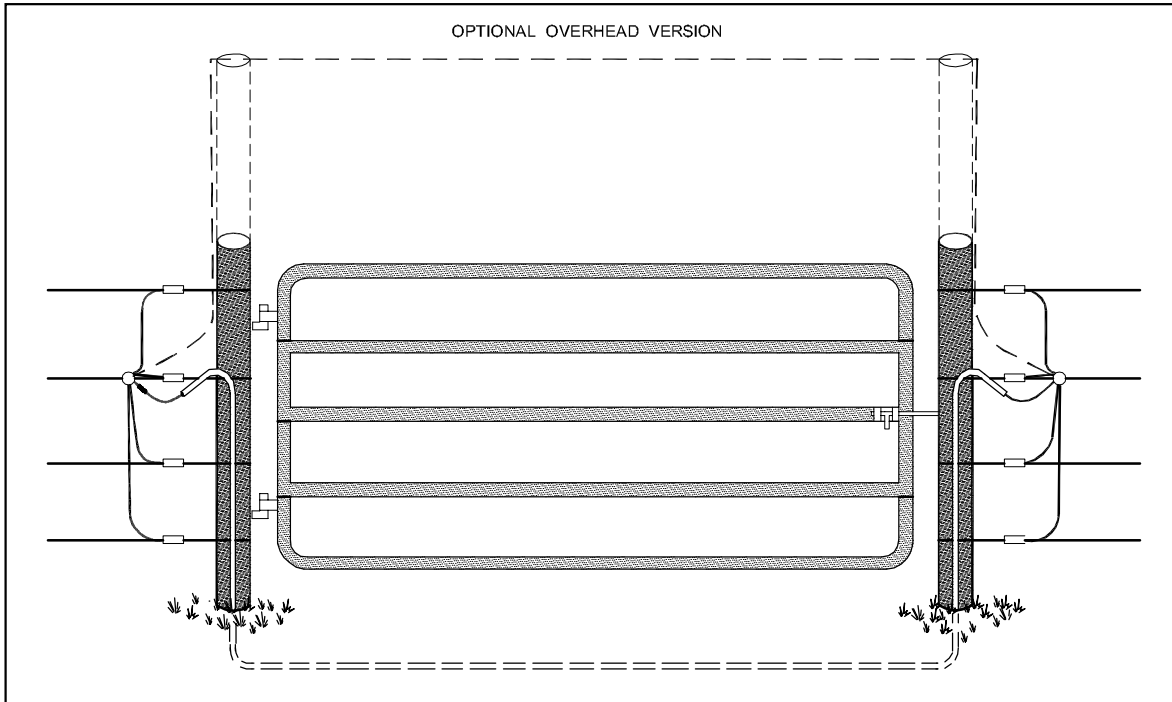

Figure 10

Electric Fence / Standard Gate

SPECIAL GATES

Cattle Guards

Cattle guards, or Texas gates, are designed to allow easy passage of vehicles while containing livestock. Although termed “cattle” guards, they are effective on most domestic animals. They may be installed adjacent to standard hinged gates where livestock passage is also required. Cattle guards are a convenience gate and are normally installed in fence lines where vehicle passage is frequent. This convenience must be weighed against any additional cost or maintenance of cattle guards over standard gates.

Cattle guards require side framing to be secure. These framing rails run from the fence and posts down to the ends of the cattle guard.

Cattle guards have not proven effective in controlling wildlife (deer out of orchards, hay fields, etc.). Tested in conjunction with deer exclusion fences, guards 10 feet wide and up to 24 feet across using 1/2 inch steel plate on edge spaced 4 inches apart did not repel deer. Full size swing gates may be the only alternative in these cases.

Cattle Guard Design

Cattle guards work on the principle that most livestock lack depth perception and by constructing an open slatted crossing over a pit they will not cross it. Painted white stripes on black pavement have been known to contain cattle.

In addition, the cattle guard slats are chosen to be difficult for livestock to walk on. Because these slats must be raised off the ground a pit or cavity is formed which must be kept clear of silt, etc. This usually requires some annual maintenance.

Temporary or Portable Cattle Guards

If a cattle guard is required for only a short period of time, low cost temporary designs are used. They are less convenient to cross than permanent guards but are easy to install.

One design is a raised wood or steel platform with an approach ramp at each end that is set on the existing road surface. No road excavation is required. This rigid platform must be strong enough for the vehicle traffic. It is removed to clean out accumulated dirt, etc. Refer to Figure 11, below.

Another temporary design is also raised above the road bed but has no approach ramp. Instead it “springs” down when driven on. It may have a shorter life than the previous design but should be lower cost as well as lighter and more portable; see Figure 12, page 15.

Permanent Cattle Guards

These designs use either pressure treated wood or steel and concrete for long life. They may be installed as a “bridge” over a ditchline or with raised road bed approaches on both sides. Either way, good access for clean out is important. In difficult situations, the cattle guard may be installed at road level over a dug pit. Sections must then be lifted out to clean the pit.

A well constructed permanent cattle guard will be 6 to 8 feet across and 10 to 16 feet wide (from side to side) over a 2 foot deep pit with good clean out access. A cattle guard design is shown in Figure 13, page 15.

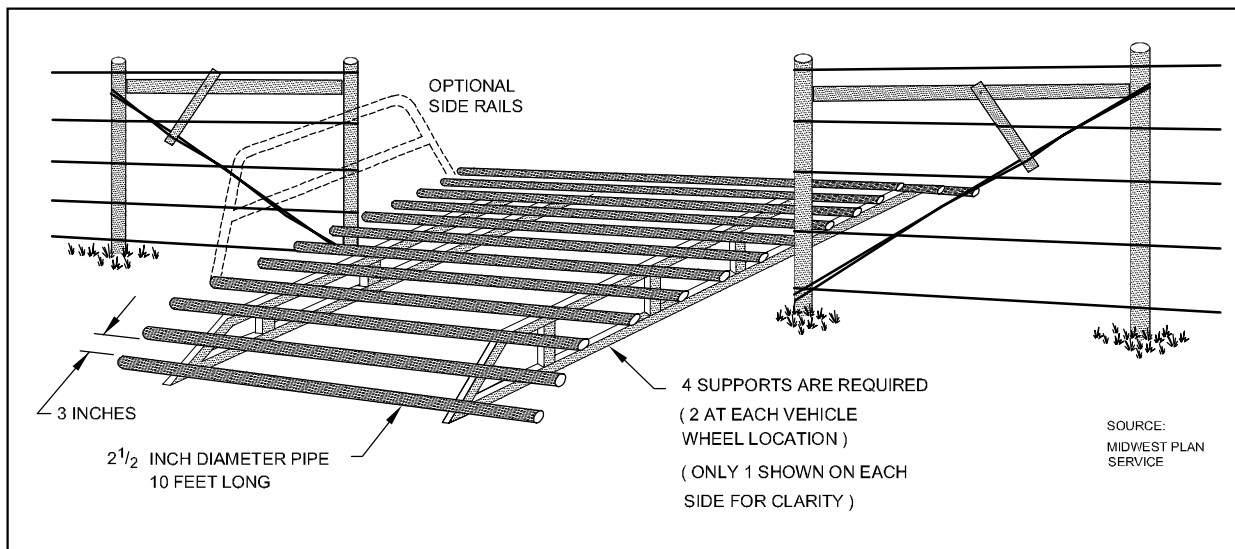

Figure 11

Rigid Temporary Cattle Guard



Figure 12 Spring-type Temporary Cattle Guards



Figure 13 Spring-type Temporary Cattle Guards

Wildlife Gates

Wildlife fencing may not be 100% effective. Should animals cross a fence, an easy exit is required in the form of a one-way gate. These function only to release animals from the farm, orchard, etc., but do not allow entry. They can commonly be seen on the Coquihalla Highway for moose and deer escapes from the road right-of-way.

Design and Installation

The gate must have one-way action, be very easy to activate, and be easily located by the animal. Gate location is important if the animal is expected to use it. Two general methods are shown in the orchard drawings in Figure 14; below. Either offset the fence line at the gate or 'funnel' the fence towards the gate. These locations are effective because the animal will follow the fence line right to the gate.

The photograph in Figure 14, below, is a highway right-of-way installation.

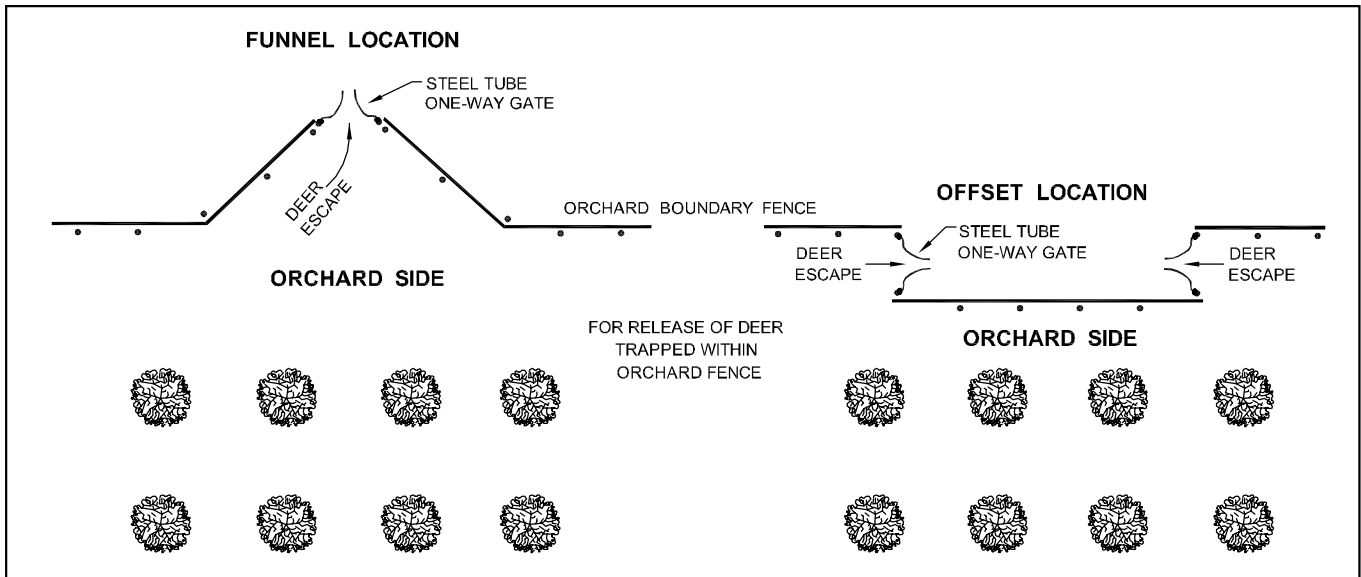

Figure 14

Wildlife Gate Locations

A typical one way gate is constructed of two sets of curved tines that are mounted vertically on spring closed hinges. The tines curve away from the enclosure side of the fence to the outside as shown in Figure 15, below.

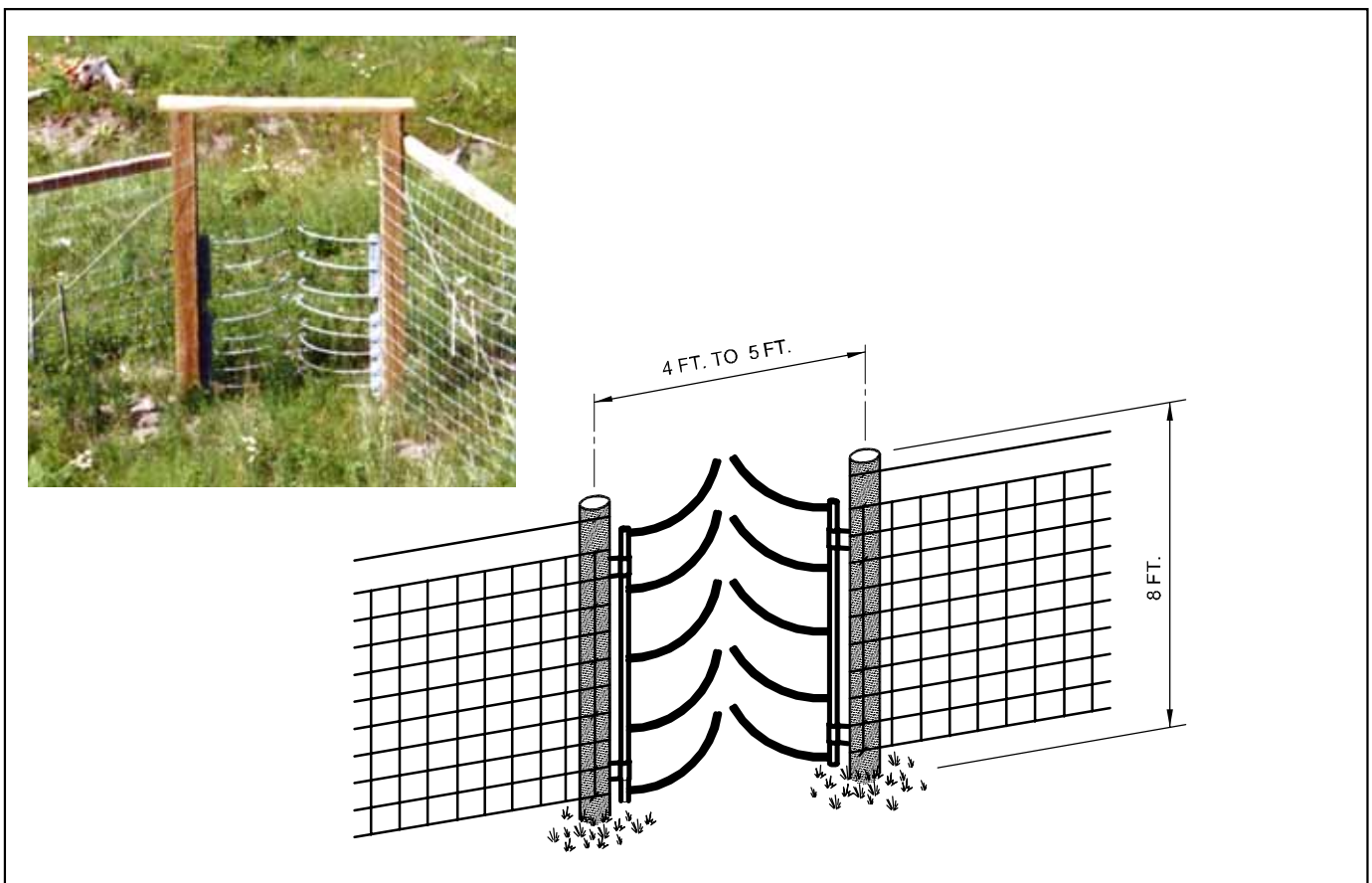

Figure 15

One-way Wildlife Gate

Passageways

Passageways are fence crossings to allow human passage only. They include hinged gates, stiles, ladders, walk throughs, step overs and safety passes as shown in Figure 16, below. They must be safe and strong and, to be effective, easy to use while being livestock proof.

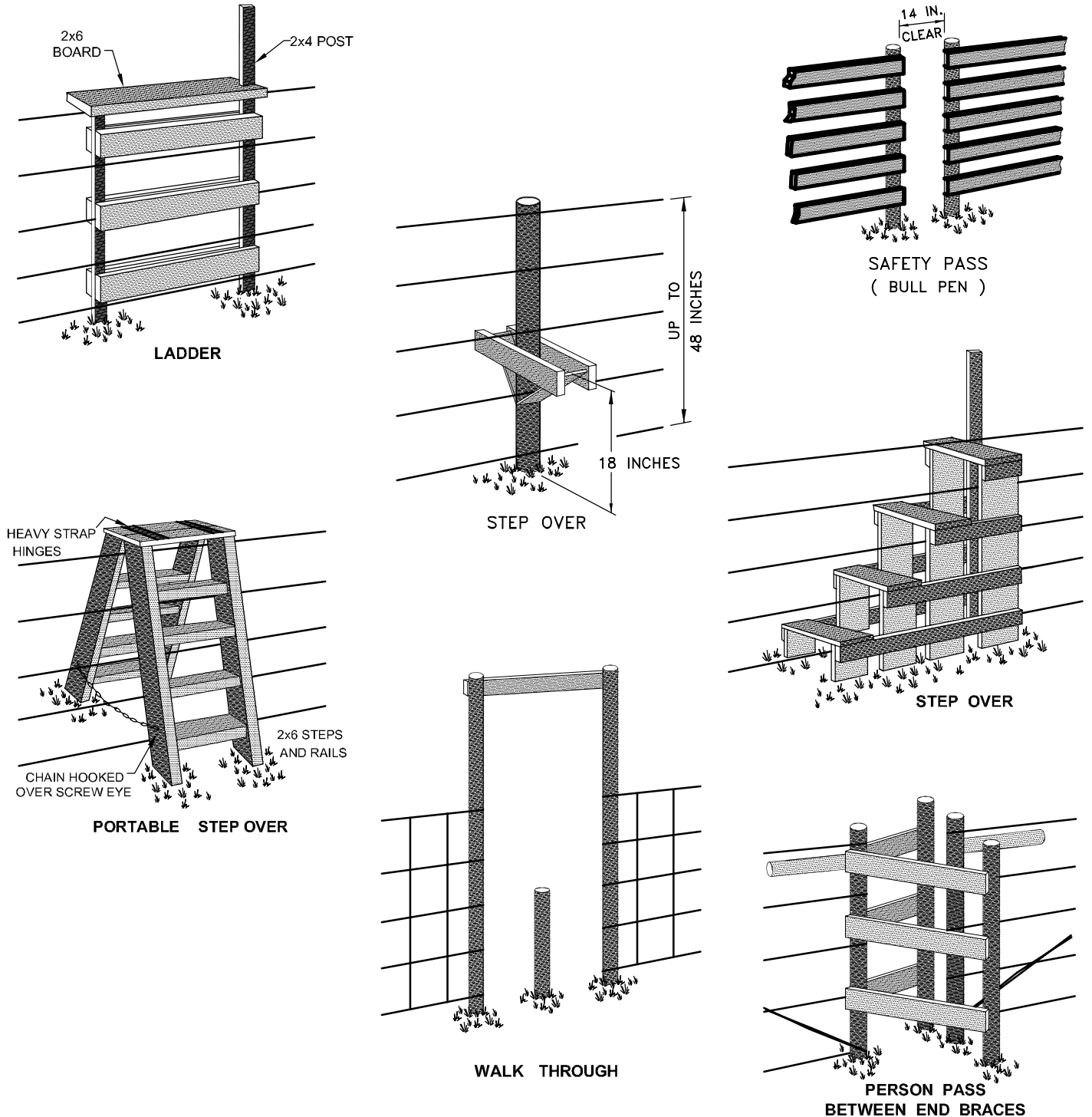

Figure 16

Passageways

Flood Gates

When fencing across small creeks or seasonal drainage gullies, it is sometimes necessary to install flood gates. These self cleaning devices will block animal movements at low water but ensure passage of water at peak flows. While various materials can be used, panels of treated wood are economical and functional. Suspended from a double wrap of high tensile smooth fence wire or light cable, wood battens are assembled to the shape of the water course. Wide flood gates will require bracing of the two line posts as shown in Figure 17, below. In the case of electric fences, the flood gate can be constructed of woven wire and electrified (only during low water) using a flexible spring connector.

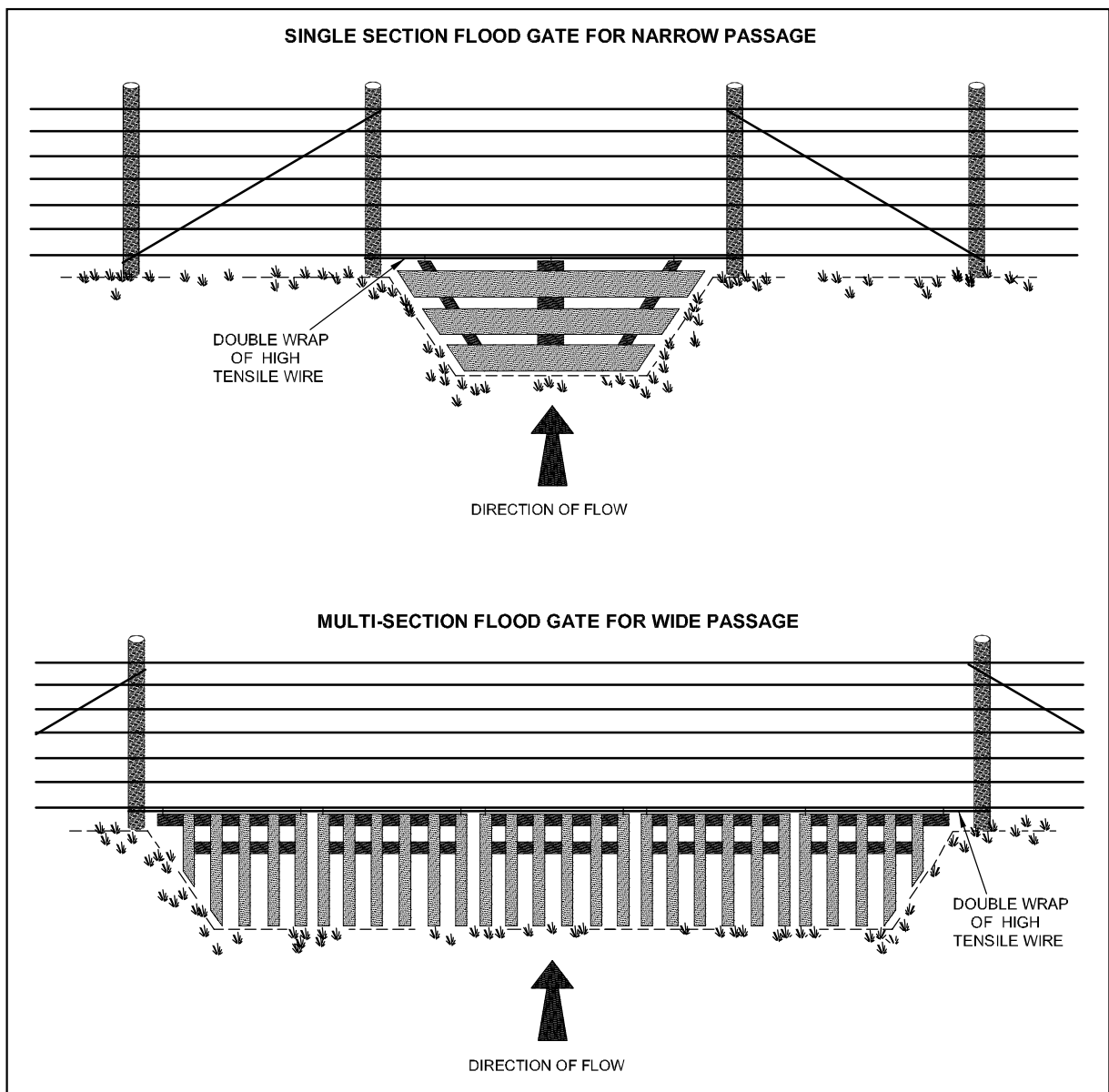

Figure 17

Flood Gates

Invisible Gates

A unique gate is available that uses electronic technology. A light beam is produced across the gate opening that triggers an alarm when interrupted. The livestock are frightened away from the opening by the combined sound and flashing light of the alarm. A button can be pressed to deactivate for passage as required.

For further information on related topics, please visit our website

Resource Management Branch

www.agf.gov.bc.ca/resmgmt

Linking to our

[Publications and Conceptual Plans](#)

FOR MORE INFORMATION CONTACT

Lance Brown, Regional Engineering Technologist

Phone: (250) 371-6064

Email: Lance.Brown@gems6.gov.bc.ca

RESOURCE MANAGEMENT BRANCH

Ministry of Agriculture, Food and Fisheries

1767 Angus Campbell Road

Abbotsford, BC V3G 2M3 Phone: (604) 556-3100